

POWERAMP[®]

**AUTOMATIC
TRUCK RESTRAINT
INSTALLATION AND
OPERATION MANUAL**

Job Name_____

Job Number_____

Serial Numbers_____

**SYSTEMS, INC.
P.O. BOX 309
Germantown, WI 53022
Phone 414-255-1510
Fax 414-255-4199**

11/96-10598

Table of Contents

Safety	1
Safety Alert Symbols	1
General Safety Precautions	1
Introduction	2-4
Installation	5-10
Light and Sign Package	10
Operating Instructions	11-12
Automatic Light Control	11
Manual Light Control	11
No Lights	11
Preventative Maintenance	13
Troubleshooting Guide	14-17
Parts Lists	18-23

Safety Alert Symbols



This Safety Alert Symbol Means ATTENTION is Involved!

The Safety Alert Symbol identifies important safety messages on equipment, safety signs, in manuals, or elsewhere. When you see this symbol, be alert to the possibility of personal injury or death. Follow the instructions in the safety message.



WARNING

The use of the word Warning signifies the presence of hazards or unsafe practices which could result in severe personal injury or death if instructions, including recommended precautions, are not followed.



WARNING

Read these safety precautions before installing, operating or servicing the truck restraint. Failure to follow the safety practices could result in serious injury or death.

CAUTION

The use of the word Caution signifies possible hazards or unsafe practices which could result in minor injury, product or property damage if instructions, including recommended precautions, are not followed.

General Safety Precautions

1. Do not operate this equipment until you read and understand the operating instructions and become thoroughly familiar with the equipment and its controls.
2. Never operate a machine while a safety device or guard is removed or disconnected.
3. Never remove Warning or Caution signs or decals on the equipment unless they are to be replaced.
4. Do not start the equipment until all other personnel in the area have been warned and have moved outside the operating zone.
5. Remove any tools or other foreign objects from the operating zone before starting.
6. Keep operating zone free of obstacles that could cause a person to trip or fall.
7. If so equipped, know EMERGENCY STOP procedures before operating.
8. Hydraulic and electrical power must be off when servicing equipment.
Note: For maximum protection, all power sources should be locked out using a lock for which only you have the key. This prevents anyone from accidentally turning on the power while you are servicing the machine.
9. Keep alert and observe indicator lights and audible alarms.
10. Do not operate faulty equipment. Make certain proper service and maintenance procedures have been performed.
11. Avoid placing fingers, hands, or any part of your body near moving parts.

Introduction

The Automatic Truck Restraint is a hydraulically activated vehicle restraint that is upwardly biased when activated. Two hooking ranges allow engagement with ICC bars that are positioned 7" to 11" from the bumper face and 12-1/2" to 30" off the drive approach. By rigidly mounting the restraint to a concrete pad or drive approach, restraining forces in excess of 22,800 pounds can be achieved. Automatic Truck Restraints may also be equipped with light communication packages that can be operator controlled or automatic.

Operation of the restraint is from atop the dock. With the truck positioned squarely against the bumper, the dock attendant depresses the "Activated" pushbutton to activate the vehicle restraint. Twin extension springs, in conjunction with a hydraulic cylinder, raise the hook vertically to meet the ICC bar. The hook maintains positive contact with the ICC bar as the trailer moves vertically during loading and unloading operations. To release the vehicle (restore the restraint), the dock attendant depresses the "Stored" pushbutton. The restraint will then lower until the storage latch is engaged.

Visual confirmation of the restraint engagement to the ICC bar is required. If the vehicle restraint cannot engage the trailer, the operator must chock the trailer tires. If equipped with lights, the operator must manually select the Bypass position on the control panel to assure proper light signals.

When the loading/unloading operation is completed, the light control switch must be switched back to the automatic position.

An integral brush shroud is utilized in the design to protect the activation mechanism from damage and minimize the collection of debris.



WARNING

Operating range of restraint should be clear of personnel at all times.

CAUTION

To prevent personal injury always operate the truck restraint from atop the dock.



WARNING

Never service a trailer that is not safely secured to the dock.



WARNING

Barricade the work area to prevent unauthorized use of the unit before installation has been completed.



WARNING

Be sure power supply circuit is opened at main service box or circuit breaker box prior to electrical installation. Failure to disconnect power supply could result in equipment damage and/or personal injury or death. Always follow proper lockout tagout procedures.

CAUTION

Have all electrical work performed only by qualified electricians.



WARNING

Do not grind or weld if hydraulic fluid or other flammable liquids are present. Always keep a fire extinguisher of the proper type nearby.

This manual covers the Automatic Truck Restraint manufactured by Systems, Inc.. Read the entire manual before installing and/or operating the truck restraint. Automatic Truck Restraints were designed to be compatible with almost all dock designs. See Figures 1 and 2.

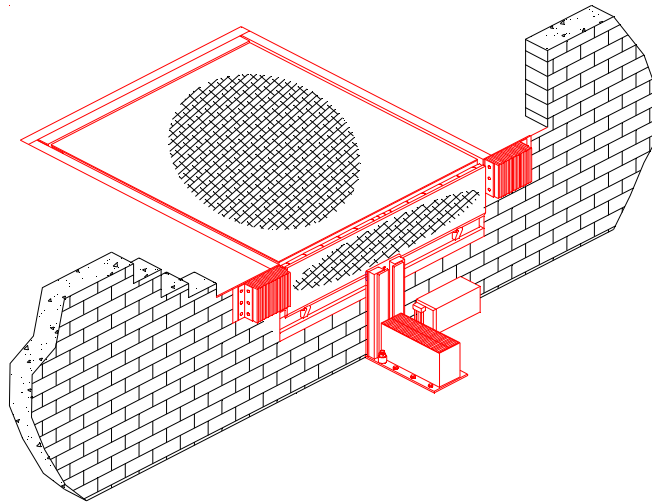

Pit Style Leveler
Figure 1

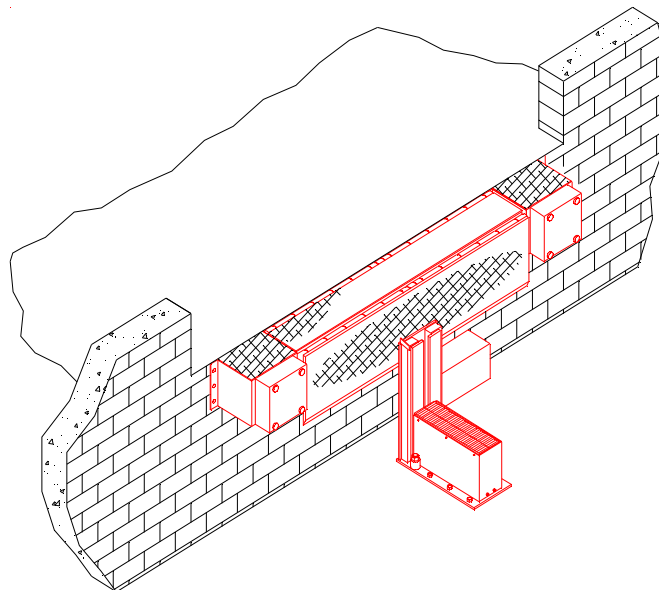

Edge of Dock
Figure 2

Automatic Truck Restraints can be accompanied by a Dock Alert II light communication package and sign kit. When installed and operated properly, the restraint will allow the dock attendants to create a safer work environment in which to work. Operation of the restraint is from atop the dock.

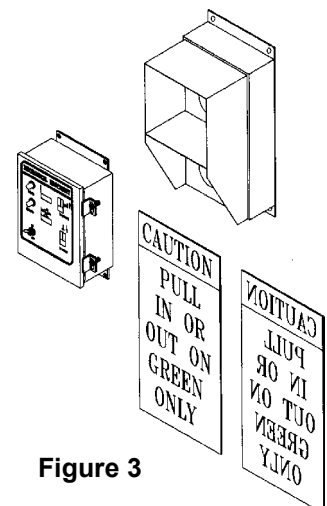
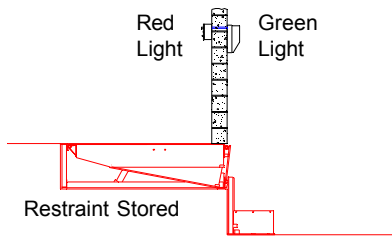
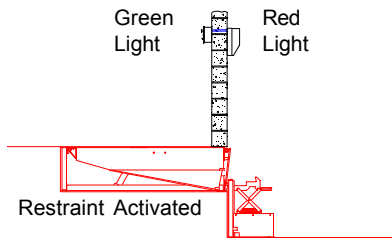

Figure 3



When not in use, the restraint must be kept in the stored position. If equipped with lights, the light selector switch should be in the automatic position. When the restraint is stored, the outside signal light is Green and the inside light is Red. See Figure 4.

Figure 4



When the restraint is activated or in use and if equipped with lights, the outside signal light is Red and the inside light is Green. See Figure 5.

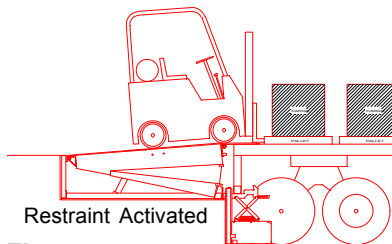
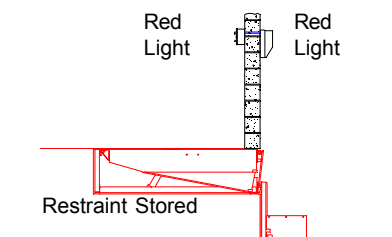

Figure 5



When no ICC bar is present or when the restraint is unable to successfully engage the ICC bar, the outside light, if equipped with a Dock Alert II light communication package can be changed to Red by switching the light control switch to Bypass. When in Bypass, the inside light & outside light are both Red whether the restraint is stored or not stored. See Figure 6.

Figure 6

Operation of the restraint is from atop the dock. Pushbutton controls allow the dock attendant to activate and store the restraint. To insure safety in and around the loading dock, dock attendants must perform the following tasks:

1. The dock attendant must activate the Automatic Truck Restraint from the control box located atop the dock. The dock attendant simply depresses the "Activated" pushbutton to raise the restraint.
2. Once the restraint has been activated, the dock attendant must visually inspect to assure that the hook has properly engaged the ICC bar. Proper engagement occurs when the hook is able to travel vertically, contacting the bottom edge of the horizontal member of the ICC bar, without obstruction. **Any missing, bent or mislocated ICC bars that do not allow for this vertical travel and/or contact are to be considered improperly engaged. When this condition occurs, it is imperative that the proper personnel, especially the truck driver, be advised. The truck/trailer must also be secured by another method to insure safety.** The restraint must be stored and, if equipped with a Dock Alert II light communication package, the selector switch (on the control box) must be turned to the bypass position during loading/unloading. After the loading/unloading process is complete, the switch must be turned back to automatic. See Figure 3.

CAUTION

Always store restraint when not in use to prevent damage.



WARNING

Read and understand operating instructions before operating.

CAUTION

Do not operate truck restraint or dock leveler until you read and understand the operating instructions and become fully familiar with the equipment and its controls.



WARNING

If truck restraint does not engage ICC bar, turn operation switch to Bypass and securely chock truck/trailer wheels. Failure to follow these instructions could result in serious personal injury or death.



WARNING

Check to make sure truck restraint hook is engaged with ICC bar before loading end loads. If restraint has been disengaged by dock leveler lip, chock truck wheels before loading end loads.



WARNING

Barricade the work area to prevent unauthorized use of the unit before installation has been completed.



WARNING

Be sure power supply circuit is opened at main service box or circuit breaker box prior to electrical installation. Failure to disconnect power supply could result in equipment damage and/or personal injury or death.

CAUTION

Have all electrical work performed only by qualified electricians.



WARNING

Do not grind or weld if hydraulic fluid or other flammable liquids are present. Always keep a fire extinguisher of the proper type nearby.

These installation instructions were written to guide you during the installation process. Please read and familiarize yourself with all sections of this manual prior to starting the installation. If you have questions about the installation or operation of the Automatic Truck Restraint, please consult the factory at (414) 255-1510 before proceeding.

Open and inspect all material upon delivery. Check contents against packing slip. Report any damage or shortages immediately to the truck line responsible.

Gather all material required for installation of restraint. Anchor kit Part #2103- 0001 supplied with the restraint consists of the following:

Item	Qty.	Part #	Description
1	2	2101-0174	Rod 1" - 8UNC GR5 x 12
2	2	2101-0175	Nut 1" - 8UNC GR5
3	6	2101-0108	Anchor 5/8" x 5" RAWL #6944
4	2	2101-0086	Washer

Additional material required to complete the restraint installation not supplied by Systems, Inc. consist of the following:

Item	Qty.	Part #	Description
1	1	2101-0177	Adhesive cartridge Rawl# 8403
2	1	2101-0178	Nozzle Rawl# 7908
3	1	2101-0179	Injection tool Rawl# 8406
4	1	N/A	1" nylon bottle brush
5	2	N/A	Anchor 3/8" as required by application.

Items listed above with System, Inc. part numbers may be purchased separately. Each adhesive cartridge should be adequate to install two restraints. Nozzles are not reusable.

1. Correct installation of the Automatic Truck Restraint requires attachment to a concrete drive greater than 6" thick. If other conditions exist, such as asphalt, a 48" wide by 48" long x 8" deep pad using a minimum of 4000 psi concrete must be poured.
2. Because of the restraint's unique design, its mounting location is referenced off the bumper face. This insures its compatibility with almost all dock designs. Properly installed bumpers, in good repair, are essential to a safe dock. If inspection of bumpers shows them to be missing, damaged or severely worn, contact your Poweramp representative to obtain replacements.
3. Position the Automatic Truck Restraint in the center of the dock/door opening with the primary (1") anchor holes located 1/2" ahead of the bumper face as shown in Figure 7. After locating and marking the primary anchor locations (qty. 2) on the drive surface, drill 1-1/8" diameter holes 7 to 7-1/2" deep. If drill breaks through concrete at a depth of less than 6", consult factory. The remaining (6) 3/4" anchor holes can be drilled at this time.

Installation



WARNING

Proper safety apparel should be worn when installing the truck restraint.

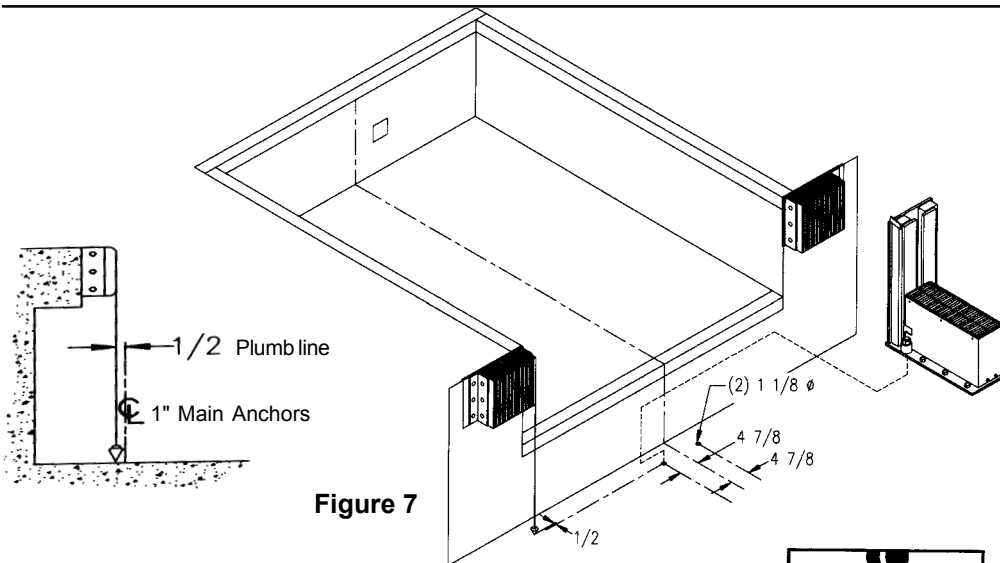

Figure 7

4. Preparation of the anchor hole is necessary to assure a long lasting installation. Prepare the 1-1/8" diameter holes in the following manner:

- A. Blow the hole clean with compressed air, brush out using 1" nylon brush, blow clean again. Holes should be clean and sound. They may be dry or damp, but should be free of standing water or frost. Be sure rod fits into hole. If larger hole is required, the diameter should be as close as possible to the rod diameter.
- B. Fill the hole approximately half way with adhesive mortar starting from the rear of the hole. Slowly withdraw the nozzle as the hole fills to avoid creating air pockets within the hole.
- C. Push the threaded rod into the hole while turning slightly to insure positive distribution of the adhesive mortar. Be sure rod is fully seated at the bottom of the hole and that the mortar has flowed from the top of the hole. If an insufficient amount of adhesive is placed in the hole, indicated by a lack of filling to the top of the hole when the rod is inserted, the rod must be extracted, additional adhesive added and rod reinserted. The threaded rod used must be free of dirt, grease, oil or other foreign material. Allow the adhesive mortar to cure for the time specified in chart prior to applying any load. See Figure 10. Do not distribute or load the anchor until it is fully cured.

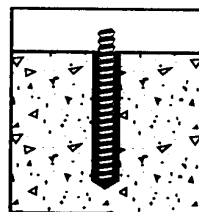
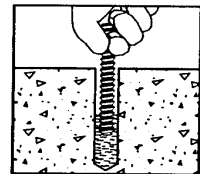
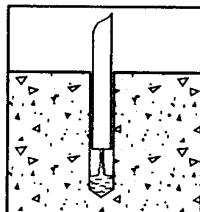
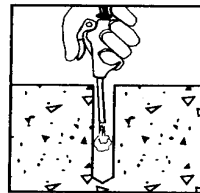
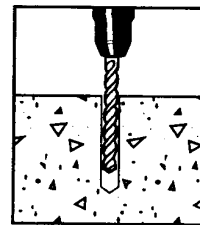

Figure 8

Handling can be simplified and line up insured if restraint is positioned over holes before rods are inserted for the final time. After adhesive has cured, adjust restraint using a bubble level, so the back is perpendicular. Shim under bottom as needed.

Installation

Install remaining six anchors using the following procedure:

Using the proper diameter bit, drill a hole into the drive approach to a depth of at least 1/2" or one anchor diameter deeper than the embedment required. The tolerances of the drill bit used should meet ANSI Standard B94.12.

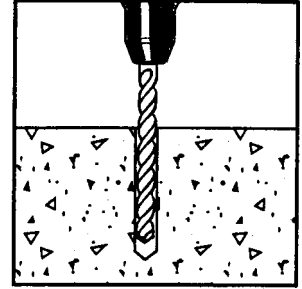

Blow the hole clean of dust and other material. Remove the inspection tag from the anchor and position the fixture. Do not expand the anchor prior to installation.

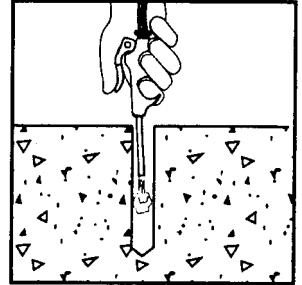

Drive the anchor through the fixture into the anchor hole until the bolt head is firmly seated against the fixture. Be sure the anchor is driven to the required embedment depth.

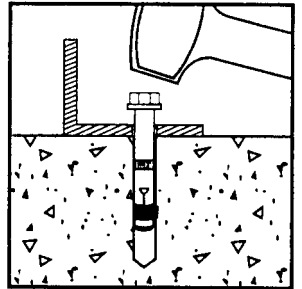

Tighten the anchor by turning the head 3 to 4 turns.

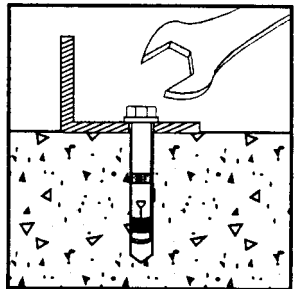

Figure 9

Base Material Temp. (F°)		Maximum Gel Time (minutes)		Minimum Curing Time (hours)		Full Curing Time (hours)	
Fast Set	Slow Set	Fast Set	Slow Set	Fast Set	Slow Set	Fast Set	Slow Set
40	40	30	60	8	16	36	48
60	60	20	45	3	7	24	36
75	75	15	35	2	6	24	24
90	90	10	20	1-1/2	4	16	24

Do not install in base material whose temperature is less than 40°F, unless job site testing is performed.

Figure 10

Installation

INSTALLATION OF ELECTRICAL COMPONENTS

When equipped with a Dock Alert II light communication package, the Automatic Truck Restraint includes a prewired control box, outside light box, and (2) outside truck driver signs and a hydraulic power unit. Components such as conduit, fittings, anchors, etc. are supplied by others. Quality workmanship using materials approved by code is required.

A typical installation will require mounting of the outside light box as shown in Figure 11. The control box mounting is generally inside the building on the left hand side of the overhead door.

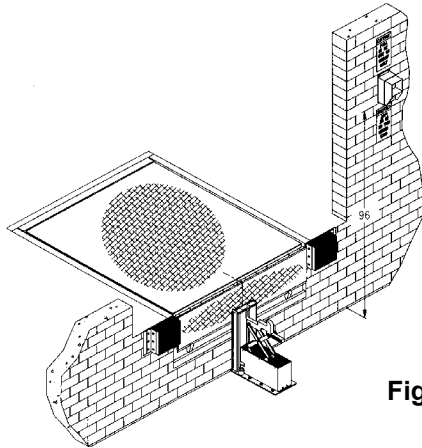

Figure 11

The location of the powerpack will vary from job to job. Figures 12 through 14 illustrate several possible locations for the powerpack. When determining a suitable location for the Powerpack, many things must be considered.

- Is the dock subject to flooding?
- Is the powerpack subject to truck/trailer damage?
- Is the powerpack subject to fork truck damage?
- Is snow removal a concern?
- Will the moving parts of a dockleveler damage the restraint?

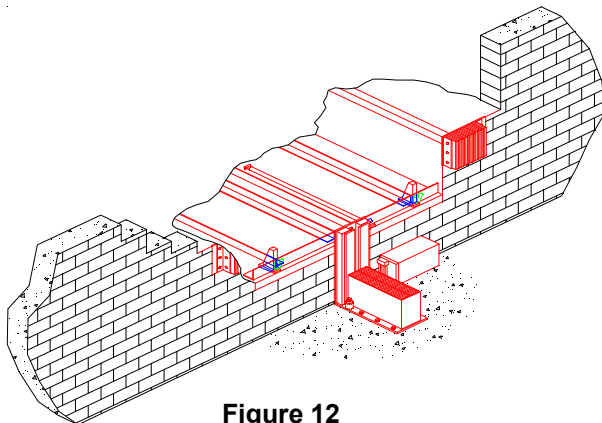

Figure 12

Figure 12 illustrates a powerpack mounting location on the dock face. In this location, flooding, snow removal and damage from trailer/trucks should be considered.

CAUTION

Have all electrical work performed only by qualified electricians.



WARNING

Be sure power supply circuit is open at main service box or circuit breaker prior to electrical installation. Failure to disconnect power supply could result in equipment damage and/or personal injury or death. Always follow proper lock out tag out procedures.

Figure 13 illustrates a mounting location on the inside building wall. In this location, damage from fork trucks must be considered. The routing of hydraulic and electrical lines from the powerpack to the restraint must be determined.

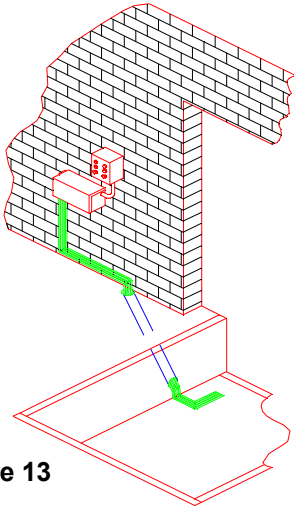

Figure 13

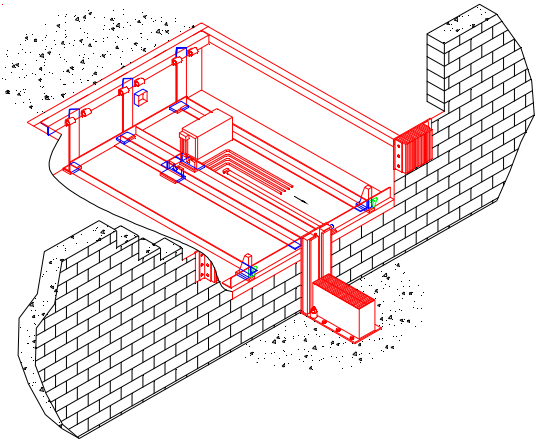

Figure 14 illustrates a mounting location under a dockleveler. In this location, damage from the moving dockleveler parts must be considered. The routing of hydraulic and electrical lines from the powerpack to the restraint must be determined.

Figure 14

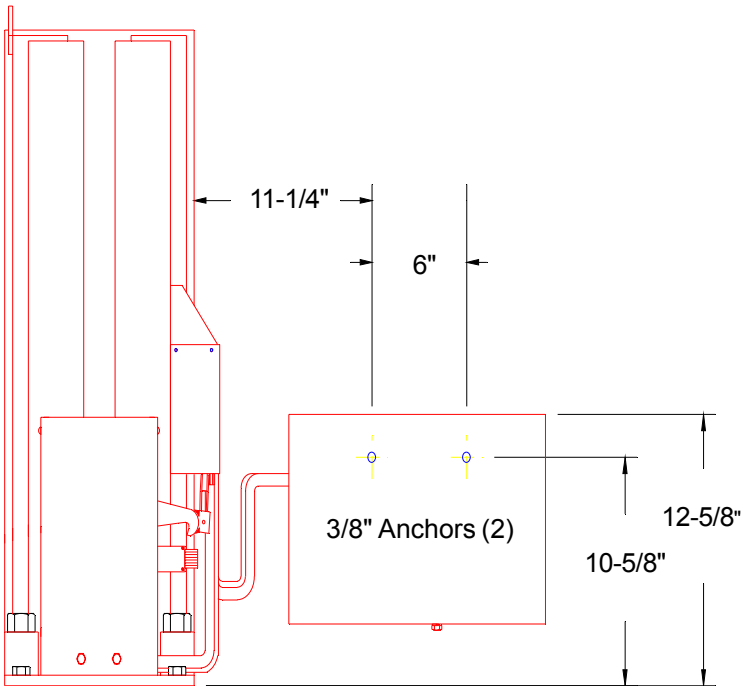
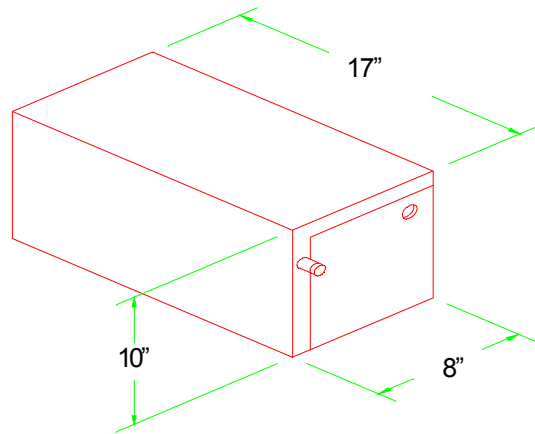

Figure 15

Installation



Conduit, flexible or rigid, must be connected between the limit switch on the restraint and the powerpack. Wiring to and from the restraint must be limited to restraint wires only. Do not run high voltage lines through the same conduit as restraint wires. Conduit and associated hardware to complete wiring and mounting of powerpack are to be supplied by others. If the powerpack will be mounted next to the truck restraint. Figure 15 illustrates the approximate location of the powerpack mounting bolts. When the powerpack is to be located inside the building on a building wall an alternative to core drilling into the pit would be to drill through the building wall as shown in Figure 16. When this installation method is selected the conduit for the Dock Alert II lights can pass through the same wall opening. Hydraulic lines and conduit must be fastened to the building to prevent damage.

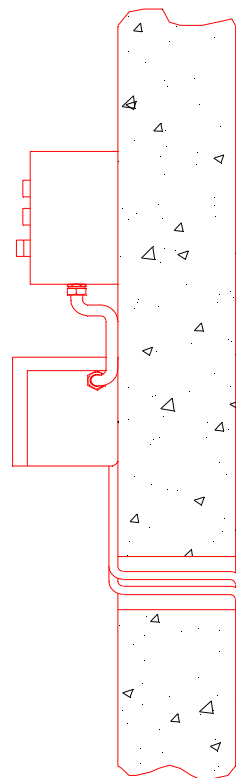

Figure 16

INSTALLATION OF SIGN

Because of the many ways signs can be mounted, hardware is not supplied. Mount the sign(s) on the right hand side, as viewed by truck driver, of restraint. The signs are usually mounted near the outside signal light permitting the truck driver to read signs from the truck.

Figure 11 provides a suggested location for mounting the signs. Good workmanship and quality materials should be used.

NOTES:

1. Some docks may have dock/truck seals (or shelters) installed or planned. Sign location and mounting should be studied before proceeding.
2. If required, signs may be trimmed for fit. **NEVER** cut or eliminate sign letters/ words.



WARNING

Do not operate the unit if any personnel are on or in front of the unit.

Do not operate the unit until the truck/trailer is parked squarely against the dock bumpers.

Do not enter the truck/trailer unless:

1. The dock leveler lip is resting securely on the truck/trailer bed.
2. The outside signal light is red, and inside signal light is green when in Automatic or red when in Bypass.
3. Either the truck/trailer ICC bar is engaged by the truck restraint or the truck/trailer wheels have been chocked.

Failure to follow these instructions could result in serious personal injury or death.



WARNING

If truck restraint does not engage ICC bar, turn selector switch to Bypass and securely chock truck/trailer wheels. Failure to follow these instructions could result in serious personal injury or death.



WARNING

Check to make sure truck restraint hook is engaged with ICC bar. Securely chock truck/trailer wheels before loading or unloading end loads.



WARNING

In Bypass operation, failure to securely chock truck/trailer wheels while loading or unloading could result in serious personal injury or death.

The Poweramp Automatic Truck Restraint was designed to work in conjunction with other dock equipment allowing the dock attendant to create a safer working environment.

Before operating the equipment, be sure the rear of the trailer has been parked tight against the face of both dock bumpers. If your loading dock is equipped with a dock leveler, the hinged lip must be in the pendant, stored position prior to operating the restraint.

Operation of the restraint will vary slightly depending on whether your restraint is equipped with a light communication package. Always operate the truck restraint from atop the dock using the operator control panel provided to prevent personal injury.

Prior to operating the equipment for the first time, check to see if the installers moved the release lever shipping bolt to the operating position. The release lever shipping bolt is located directly above the release lever (see item . Failure to move this bolt will result in a non-operational restraint.

OPERATION WITH AUTOMATIC LIGHTS

The following procedure can be used for operating Automatic Truck Restraints equipped with automatic lights.

1. Verify that the light control switch is in the "Automatic" position, and that a red light is illuminated inside with a green light illuminated outside.
2. Verify that the trailer is parked tight against both bumpers.
3. Depress the "Activate" pushbutton on the control panel.
4. Visually inspect and confirm that the truck restraint arm has travelled vertically and has engaged the horizontal member of the ICC bar. Visually verify that the outside light has switched to red and that the activated light inside is illuminated. If the restraint has not engaged the ICC bar, turn selector switch to Bypass and secure the trailer by other safety means prior to activating dockleveler.
5. Activate dock leveler so that the lip is positioned in the rear of the trailer and proceed to load/unload.
6. When loading/unloading of truck is completed, return the dock leveler to the stored position.
7. Depress the "Store" pushbutton on the control panel.
8. Verify that the inside light has changed and that the stored red light is now illuminated.

OPERATION WITHOUT LIGHTS

1. Verify that the trailer is parked tight against both bumpers.
2. Depress the "Activate" pushbutton on the control panel.
3. Visually inspect and confirm that the truck restraint arm has traveled vertically and has engaged the horizontal member of the ICC bar. If the restraint has not engaged the ICC bar, secure the trailer by other safety means, such as wheel chocks, prior to activating the dock leveler.

Operation

4. Activate the dock leveler and proceed to load/unload.
5. When loading/unloading of the truck is complete, return the dock leveler to the stored position.
6. Depress the "Store" pushbutton on the control panel and verify that the unit has stored.



WARNING

Always barricade the work area to prevent unauthorized use of the unit before maintenance is complete.

If powerpack is stored under dock leveler in pit, always lock off all electrical disconnects after raising platform and setting maintenance prop when service under the unit is required. More than one electrical disconnect switch may be required to de-energize the equipment.

Always stand clear of the dockleveler lip when working in front of the unit.



WARNING

Failure to check and repair or replace if required, lights and/or alarm will jeopardize dock attendant safety.

MAINTENANCE

1. Good housekeeping practice is the most commonly needed truck restraint requirement. Shipping and receiving docks are notorious for having wood scraps, steel banding and other debris laying at the front of the dock. Daily patrol truck restraint area and clean up dock.
2. Depending on the type of application, the Automatic Truck Restraints usually require lubrication every three months. Lubricate back track with an anti-seize lubricant. Lubricate linkage with 30 wt. oil.
3. **IMPORTANT:** Inspect daily and test the inside and outside signal lights. **THEY MUST WORK.** Replace broken light bulb as required.
4. Repair or replace signs if required.
5. **IMPORTANT:** Truck restraint must be protected by dock bumpers. Worn, torn, loose or missing bumpers must be replaced. Contact your local Poweramp representative for replacement bumpers.
6. Perform operational tests after all repairs and adjustments.
7. Check hydraulic fluid level with restraint raised. Put selector/power switch in "off" position. Remove breather from tank. Oil should be approximately one (1) inch from top of tank.

Hydraulic Fluid - to assure normal operating in an ambient temperature range of -30 degrees to +125 degrees Fahrenheit these fluids are recommended:

Aero Shell Fluid #4 Code #60421 by Shell Oil Co.

Mobil Aero HFA Mil-H5606A by Mobil Oil Co.

Texaco Type BB

Filmite No. 530

Exxon "Univis J13"

Note: Hydraulic fluids with equivalent specifications may be used.

Troubleshooting



WARNING

Always barricade the work area to prevent unauthorized use of the unit during repair or maintenance procedures.

Always lock OFF all electrical disconnects when servicing the unit. Always stand clear of the dockleveler lip when working in front of the unit. Never work in the operating range of the restraint with power ON.

Always check and either repair or replace burned out lights. Failure to do so could jeopardize dock attendant's safety.

Perform the following procedures prior to beginning detailed troubleshooting:

- A. Check all fuses inside the control assembly. Replace any bad fuse with one of equivalent specification.
- B. Confirm presence of necessary voltages inside the control assembly.
- C. Make sure the thermal overload on the motor has not tripped. (Motor has an integral thermal protector that automatically resets).

Mechanical Troubleshooting

Problem	Possible Solution(s)
Carriage will not raise.	1. Check side release lever--it may be bound and not releasing.
	2. Check restraint body for debris which may bind operation.
	3. Check for broken extension springs.
	4. Check link joints for missing or bent shoulder bolts, pins or excessive wear.
	5. Joints are permanently lubricated bushings and should not require oiling, however, rubbing surfaces of links should be lubricated per maintenance section of this manual.
Carriage will not lower or lock down.	1. Check side release lever--it may be bound and not engaging.
	2. Check restraint body for debris which may bind operation.
	3. Check link joints for missing or bent shoulder bolts, pins or excessive wear.
	4. Joints are permanently lubricated bushings and should not require oiling, however, the rubbing surfaces of links should be lubricated per maintenance section of this manual.
	5. On occasion, a truck may move forward, trapping the ICC bumper maintaining a positive engagement. To unlock the restraint carriage, it may be necessary for the truck to back up.

Troubleshooting

Hydraulic Troubleshooting

Problem	Possible Solution(s)
Restraint will not raise.	1. Remove excess load from restraint. Unit is designed to raise no more than its own weight as a safety feature.
	2. Strainer element plugged. Remove reservoir and clean or replace strainer element.
Restraint moves very slowly.	1. Low hydraulic fluid. Add hydraulic fluid as needed.
	2. Pump by-pass set too low. Pump by-pass adjustment is internal to pump, consult factory.
Restraint moves in one direction only regardless of button pushed.	1. 4 way valve stuck in either position. Locate solenoid. Remove coil from spool and spool from valve block. check spool for contaminants and/or damage. Replace spool if damaged. Carefully wipe off spool with clean rag (do not damage "O" rings on spool) Check valve block for contaminants. Replace spool in block and coil on spool. DO NOT overtighten spool into block. Maximum tightening torque for spool is 35-40 lb./ft. DO NOT overtighten coil on spool. Operate the unit. Replace spool if problem persists and all other troubleshooting procedures performed.

Electrical Troubleshooting

PROBLEM	POSSIBLE SOLUTION(S)
<p>Restraint does not raise or lower - Motor does not run, inside & outside lights do not work.</p>	<p>1. No voltage at control assembly. Check voltage input.</p>
	<p>2. Blown fuse inside control assembly. Use voltmeter to test.</p>
	<p>WARNING: LINE SIDE OF FUSE IS ALWAYS HOT. LOCK OFF POWER TO CONTROL ASSEMBLY BEFORE REMOVING FUSE.</p>
	<p>3. Defective contact block at power selector switch. Use voltmeter to test.</p>
<p>Restraint does not raise or lower - motor hums but does not run, inside & outside lights work.</p>	<p>1. Voltage too low. Check for low voltage. Increase wire size to correct voltage drop.</p>
	<p>2. Defective capacitor. Disconnect capacitor. Test.</p>
	<p>CAUTION: DISCHARGE CAPACITOR BEFORE ATTEMPTING A CAPACITOR TEST.</p>
<p>Restraint does not raise - motor runs in pressure relief, inside & outside lights work.</p>	<p>1. Solenoid coil not electrically energizing. Check coil for magnetism. Use voltmeter to test voltage at coil.</p>
	<p>2. Solenoid spool mechanically stuck OFF. Remove spool from hydraulic block. Inspect spool & block for contaminants. Test. Restraint if necessary.</p>
	<p>NOTES:</p>
	<p>DO NOT RUN MOTOR WHEN SPOOL IS REMOVED FROM BLOCK.</p>
	<p>DO NOT OVERTIGHTEN COIL ON SPOOL. NUT IS TO ONLY BE TIGHTENED TO PREVENT COIL FROM FALLING OFF SPOOL.</p>
	<p>DO NOT OVERTIGHTEN SPOOL INTO BLOCK. SPOOL IS ONLY TO BE TIGHTENED TO PREVENT FLUID EXIT FROM BLOCK VIA SPOOL WHEN UNIT OPERATING.</p>
<p>Restraint does not raise - motor does not run, inside & outside lights work.</p>	<p>1. Defective contact block at activated pushbutton. Use voltmeter to test.</p>
	<p>2. No voltage at motor. Use voltmeter to test voltage at motor.</p>
	<p>3. Thermal protector inside motor has tripped. Wait for protector to reset.</p>

Electrical Troubleshooting - Continued

PROBLEM	POSSIBLE SOLUTION(S)
<p>Restraint does not lower - motor runs in pressure relief, inside & outside lights work.</p>	<p>1. Solenoid spool mechanically stuck ON. Remove spool from hydraulic block. Inspect block for contaminants. Test. Replace if necessary.</p>
	<p>NOTES:</p>
	<p>DO NOT RUN MOTOR WHEN SPOOL IS REMOVED FROM BLOCK.</p>
	<p>DO NOT OVERTIGHTEN COIL ON SPOOL. NUT IS TO ONLY BE TIGHTENED TO PREVENT COIL FROM FALLING OFF SPOOL.</p>
	<p>DO NOT OVERTIGHTEN SPOOL INTO BLOCK. SPOOL IS ONLY TO BE TIGHTENED TO PREVENT FLUID EXIT FROM BLOCK VIA SPOOL WHEN UNIT OPERATING.</p>
<p>Restraint does not lower - motor does not run, inside & outside lights work.</p>	<p>1. Obstruction activating limit switch lever. Remove obstruction. Make sure lever operates freely.</p>
	<p>2. Defective limit switch. Use voltmeter to test switch contact operation.</p>
	<p>3. Defective control relay(s). Use voltmeter to test voltage at relay(s) coil & to test relay(s) contact operation.</p>
	<p>4. No voltage at motor. Use voltmeter to test voltage at motor.</p>
	<p>5. Thermal protector inside motor has tripped. Wait for protector to reset.</p>
<p>Light(s) does not work or light(s) does not work correctly - restraint raises & lowers.</p>	<p>1. Defective bulb. Replace.</p>
	<p>2. Obstruction preventing activation or deactivation of limit switch lever. Remove obstruction. Make sure lever operates freely.</p>
	<p>3. Defective limit switch. Use voltmeter to test switch contact operation.</p>
	<p>4. Defective control relay. Use voltmeter to test voltage at relay coil & to test relay contact operation.</p>
	<p>5. Defective contact block(s) at light control selector (or key) switch. Use voltmeter to test.</p>

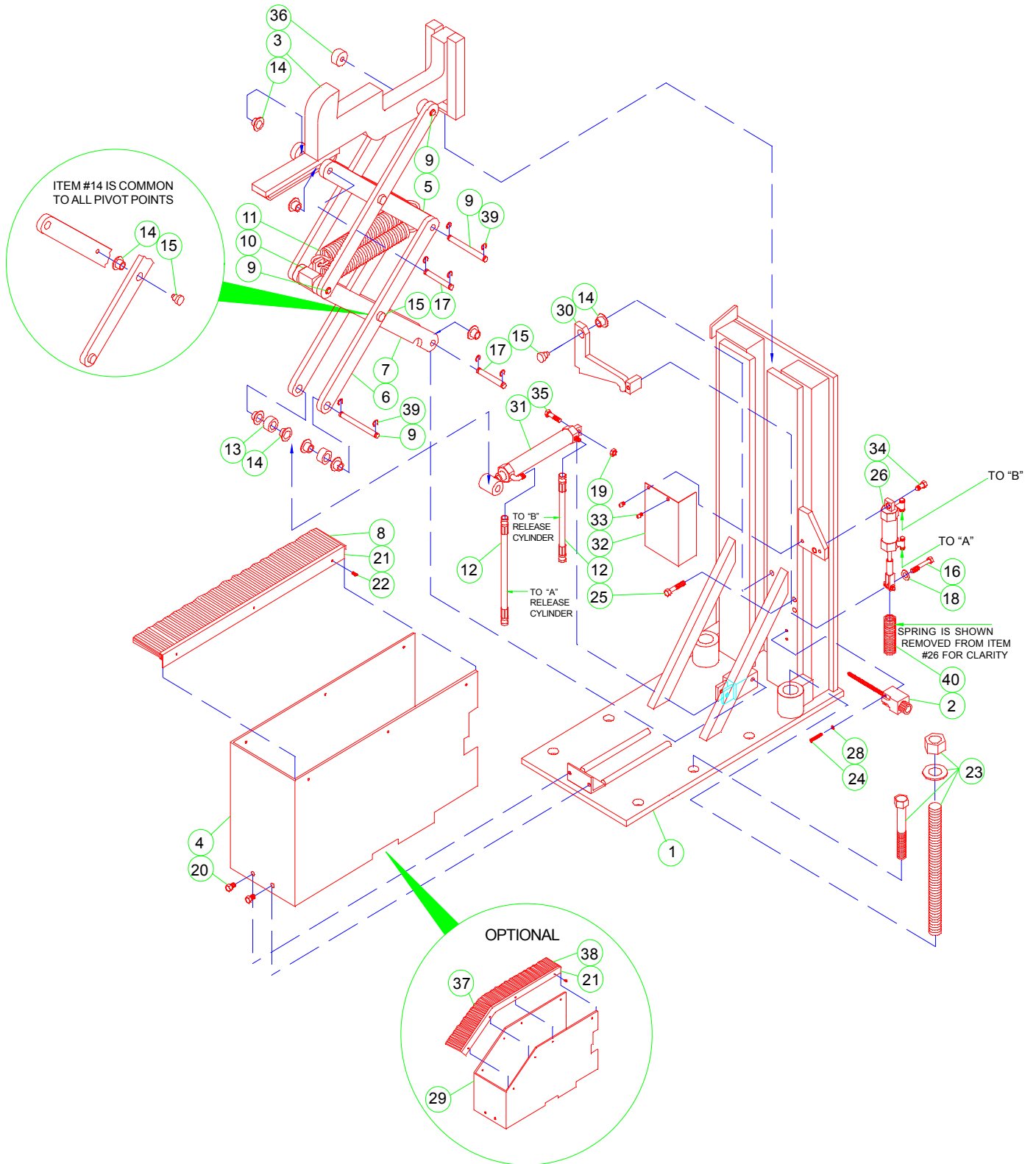

Figure 18

BILL OF MATERIALS

ITEM	QTY	PART NUMBER	DESCRIPTION
1	1	9414-0035	BASE WELDMENT
2	1	0961-0148	LIMIT SWITCH
3	1	9413-0049	RESTRAINT WELDMENT
4	1	9411-0023	SHROUD
5	3	9412-0148	BAR LINK - TAPPED CENTER
6	4	9412-0149	BAR LINK
7	1	9412-0187	BAR LINK W/TAPPED CENTER & NOTCH
8	2	0192-0053	BRUSH - WEATHERSEAL
9	4	9202-0042	PIN - LONG
10	2	9413-0044	SPRING PLATE WELDMENT
11	2	0941-0011	SPRING EXTENSION
12	2	9904-0097	HOSE ASSY 1/4" 100 R1 X 24"
13	2	9412-0185	ROLLER
14	23	9461-0006	FLANGED SHOULDER BEARING - BRONZE
15	5	2101-0165	SOCKET HEAD SHOULDER SCREW
16	1	2101-0098	HEX HEAD CAP SCREW GRADE 5
17	2	9202-0043	PIN - SHORT
18	1	2101-0163	FLAT WASHER
19	3	2101-0039	HEX HEAD NUT
20	2	2101-0057	HEX HEAD CAPSCREW
21	2	0192-0052	TRACK - WEATHERSEAL
22	6	2101-0180	SCREW - PHILIPS
23	1	2103-0001	ANCHOR KIT
24	2	2101-0182	SCREW-PHILLIPS
25	1	2101-0018	HEX HEAD CAP SCREW GRADE 2
26	1	0524-0063	HYDRAULIC CYLINDER - RELEASE
27	1	2101-0181	SOCKET HEAD SHOULDER SCREW
28	2	2101-0156	LOCK WASHER
* 29	1	9411-0025	SHROUD - TAPERED
30	1	9413-0051	RELEASE LEVER WELDMENT
31	1	0524-0064	HYDRAULIC CYLINDER - STORE
32	1	9411-0024	SHROUD - RELEASE CYLINDER
33	2	2101-0133	MACHINE SCREW - ROUND HEAD
34	1	2101-0187	HEX HEAD CAPSCREW GRADE 5
35	1	2101-0188	HEX HEAD CAPSCREW GRADE 5
36	2	9412-0161	BOSS
* 37	2	0192-0056	BRUSH WEATHERSEAL
* 38	2	0192-0057	BRUSH WEATHERSEAL
39	12	2101-0189	E CLIP
40	1	0941-0012	SPRING

*** OPTIONAL: ITEM# 29, 37 & 38 REPLACES ITEM #4 & 8.
ITEM #22 QUANTITY CHANGES FROM 6 TO 8.**

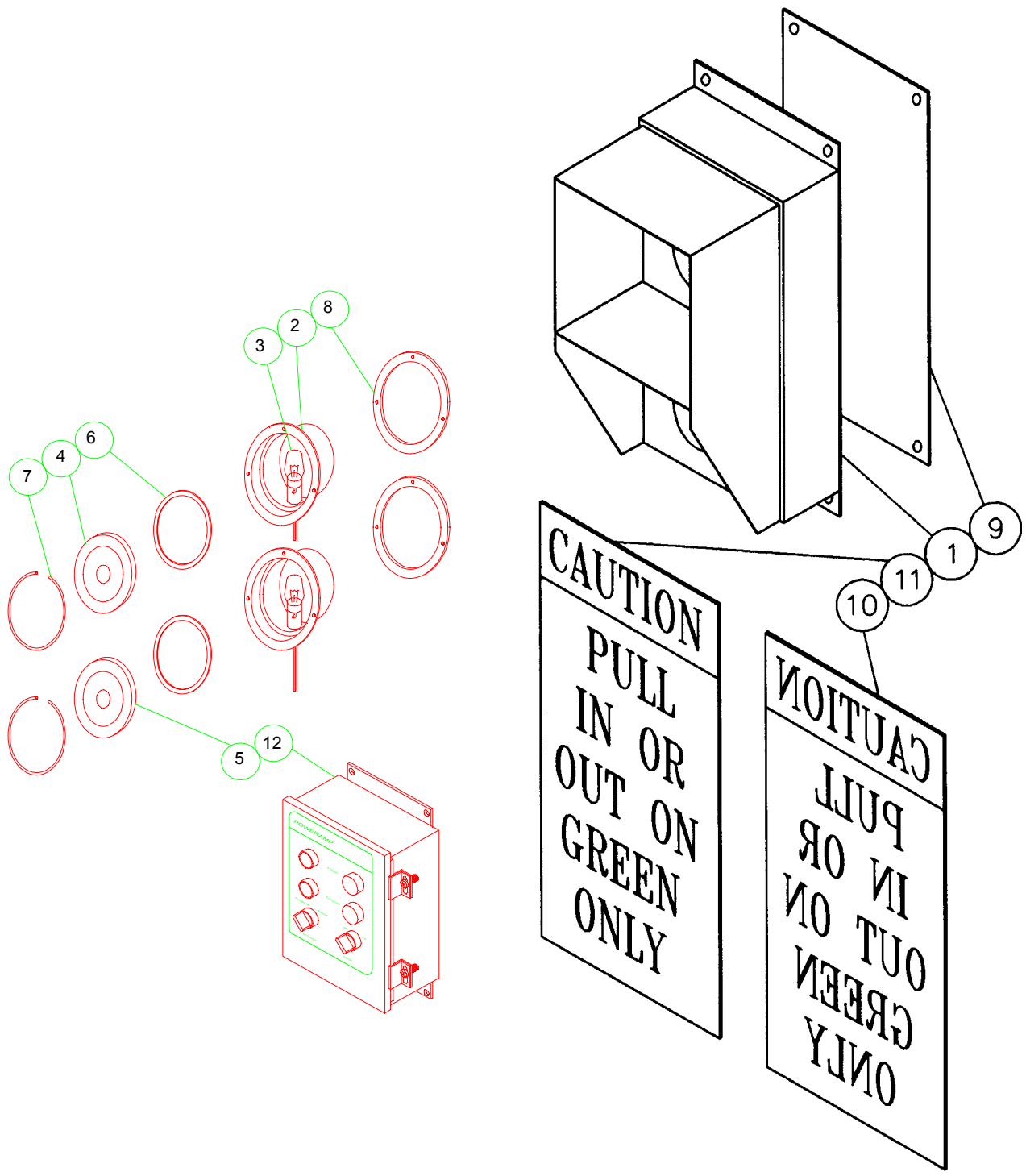

Figure 18

BILL OF MATERIALS

ITEM	QTY.	PART NUMBER	DESCRIPTION
1	1	7154-0002	SIGNAL LIGHT HOUSING ASSY.
2	2	7153-0006	LIGHT ASSEMBLY
3	2	3051-0046	10 WATT LAMP (GE 10C7DC)
4	1	7151-0002	RED LENS
5	1	7151-0003	GREEN LENS
6	2	7151-0026	LENS GASKET
7	2	7151-0011	SNAP RING
8	2	7151-0006	LIGHT ASSEMBLY GASKET
9	1	7152-0006	BACK PLATE
10	1	1751-0034	CAUTION SIGN - MIRRORRED
11	1	1751-0033	CAUTION SIGN
12	1	9-K0-000-0-B	CONTROL BOX W/AUTO/MANUAL DOCK ALERT

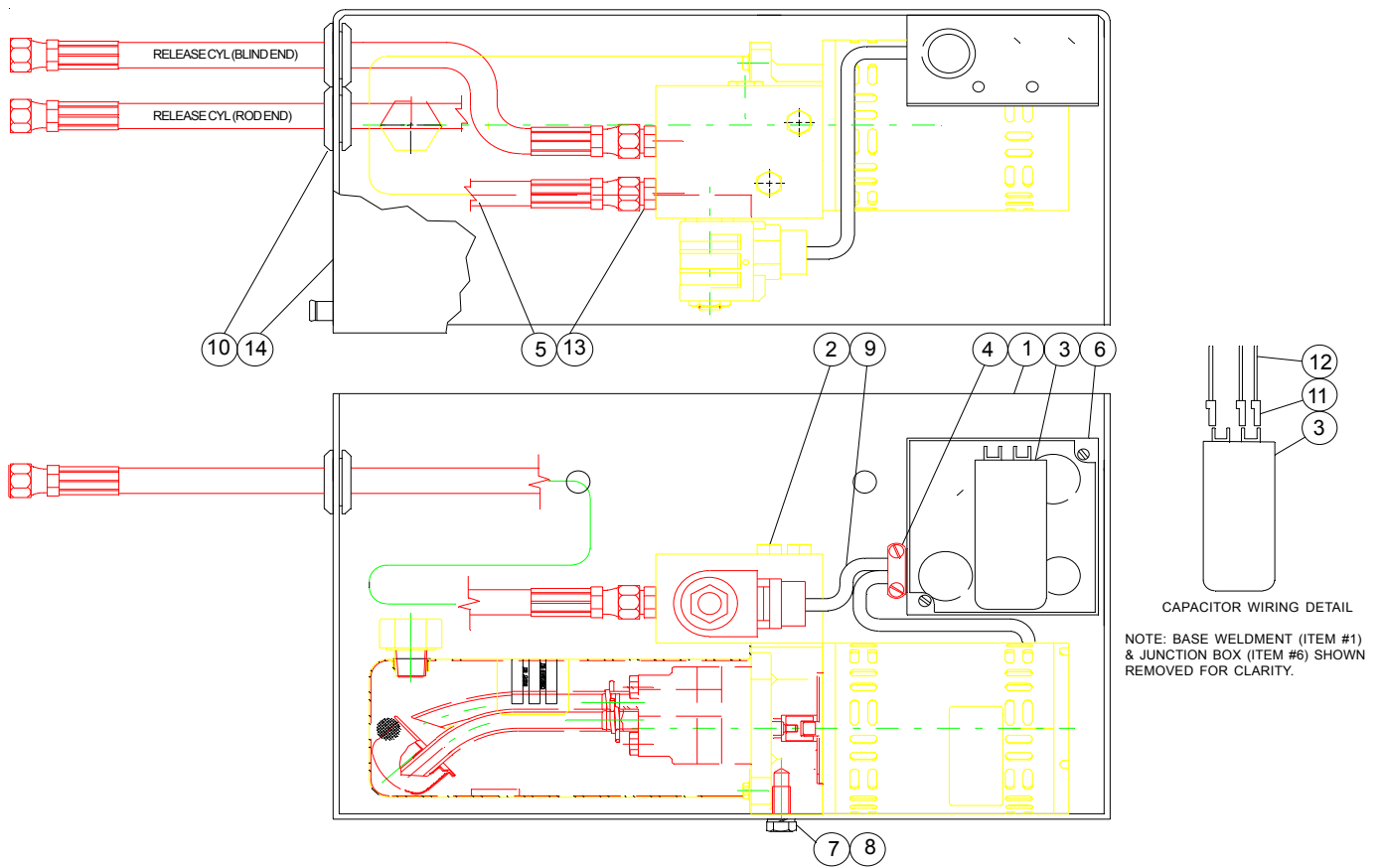

Figure 19

BILL OF MATERIALS

ITEM	QTY.	PART NUMBER	DESCRIPTION
1	1	9393-0025	BASE WELDMENT
2	1	9391-0009	POWERPACK
3	1	3051-0058	CAPACATOR
4	1	1431-0011	CONNECTOR - 2 SCREW
5	2	9904-0097	HOSE ASSEMBLY X 24"
6	1	2751-0016	COVER - J-BOX
7	2	2101-0140	LOCK WASHER
8	2	2101-0017	HEX HEAD CAPSCREW
9	2	R598-0090	SPLIT FLEXIBLE CONDUIT
10	2	6431-0001	GROMMET
11	3	1431-0035	INSULATED TERMINAL
12	1	R513-0050	WIRE
13	2	9301-0164	CONNECTOR
14	1	9391-0013	COVER (SHOWN PARTIALLY IN TOP)