



POWERSTOP-M TRUCK RESTRAINT INSTALLATION AND OPERATION MANUAL

Job Name _____
Job Number _____
Serial Numbers _____

Systems, Inc.
P.O. Box 309
Germantown, WI 53022
Phone: (262) 255-1510
Fax: (262) 255-4199

Table of Contents

Safety	1
Safety Alert Symbols	1
General Safety Precautions	1
Introduction	2-3
Installation	4-7
Mechanical Restraint Light and Sign Package	7
Operating Instructions	8-9
Automatic Light Control	8
Manual Light Control	9
No Lights	9
Preventative Maintenance	10
Troubleshooting Guide	10-11
Parts Lists	12-15

Safety Alert Symbols



This Safety Alert Symbol Means ATTENTION is Involved!

The Safety Alert Symbol identifies important safety messages on equipment, safety signs, in manuals, or elsewhere. When you see this symbol, be alert to the possibility of personal injury or death. Follow the instructions in the safety message.



WARNING

The use of the word “Warning” signifies the presence of hazards or unsafe practices which could result in severe personal injury or death if instructions, including recommended precautions, are not followed.

CAUTION

The use of the word “Caution” signifies possible hazards or unsafe practices which could result in minor injury, product or property damage if instructions, including recommended precautions, are not followed.

General Safety Precautions

1. Do not operate this equipment until you read and understand the operating instructions and become thoroughly familiar with the equipment and its controls.
2. Never operate a machine while a safety device or guard is removed or disconnected.
3. Never remove Warning or Caution signs or decals on the equipment unless they are to be replaced.
4. Do not start the equipment until all other personnel in the area have been warned and have moved outside the operating zone.
5. Remove any tools or other foreign objects from the operating zone before starting.
6. Keep operating zone free of obstacles that could cause a person to trip or fall.
7. If so equipped, know EMERGENCY STOP procedures before operating.
8. Hydraulic and electrical power must be off when servicing equipment.
Note: For maximum protection, all power sources should be locked out using a lock for which only you have the key. This prevents anyone from accidentally turning on the power while you are servicing the machine.
9. Keep alert and observe indicator lights and audible alarms.
10. Do not operate faulty equipment. Make certain proper service and maintenance procedures have been performed.
11. Avoid placing fingers, hands, or any part of your body near moving parts.
This manual covers the mechanical truck restraint manufactured by

Introduction

Poweramp. Read the entire manual before installing and/or operating the truck restraint. Poweramp mechanical truck restraints were designed to be compatible with almost all dock designs. See Figures 1 and 2.

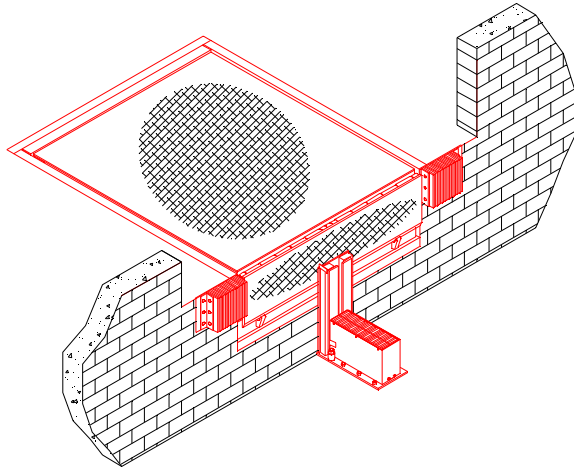

Figure 1
Pit Style Leveler

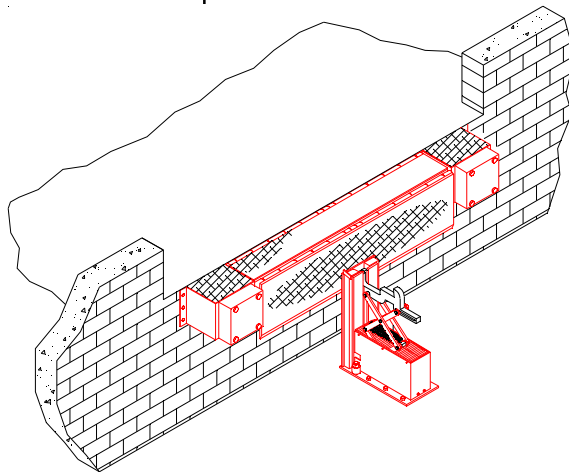

Figure 2
Edge of Dock

Poweramp mechanical restraints can be accompanied by a Dockalert light communication package and sign kit. When installed and operated properly, the mechanical restraint will allow the dock attendants to create a safer work environment in which to work.

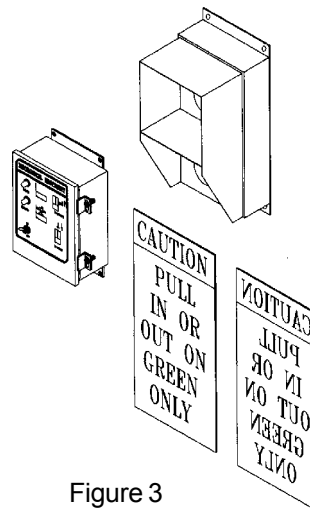

Figure 3

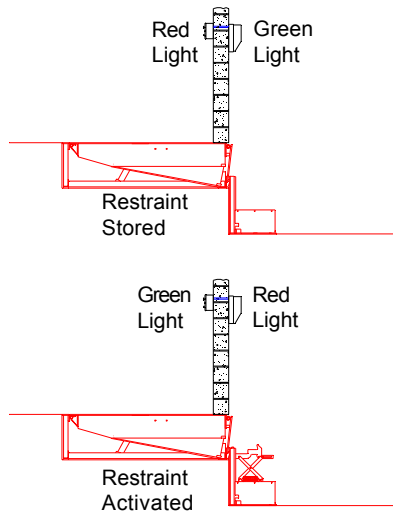

Figure 4

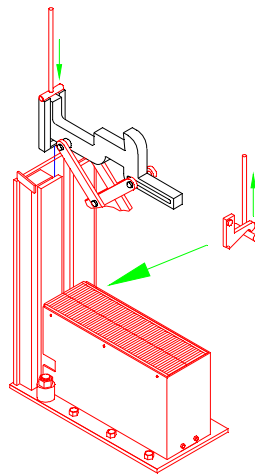
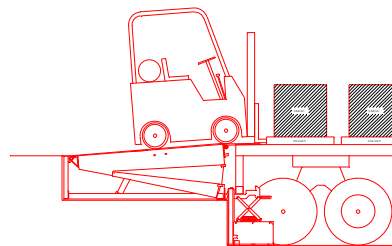

Figure 5



Restraint Activated

Figure 6

When not in use, the restraint must be kept in the stored position. If equipped with lights, the light selector switch should be in either the automatic or stored position depending on restraint model. Units equipped with automatic light operation should have the light control switch placed in the automatic position. Units equipped with manual light operation must have the light control switch placed in the position that matches the restraint position. When the mechanical truck restraint is stored, the outside signal light is Green and the inside light is Red. See Figure 4.

Operation of the restraint is from atop the dock. A lifting hook is used from atop the dock to release and store the restraint. To insure safety in and around the loading dock, dock attendants must perform the following tasks:

1. For those units equipped with manually operated lights, the operator must switch the light control switch to the activated position prior to loading/unloading. This will change the outside signal light to Red.
2. After switching the light control to the activated position, the dock attendant must activate the mechanical truck restraint. This is done by using the operating bar from atop the dock to lift up on the release lever. The release lever is located on the right side of the restraint when viewed from atop the dock.
3. Once the restraint has been activated, the dock attendant must visually inspect to assure that the hook has properly engaged the ICC bar. Proper engagement occurs when the hook is able to travel vertically, contacting the bottom edge of the horizontal member of the ICC bar, without obstruction. Any missing, bent or mislocated ICC bars that do not allow for this vertical travel and/or contact are to be considered improperly engaged. When this condition occurs, it is imperative that the proper personnel, especially the truck driver, be advised. The truck/trailer must also be secured by another method to insure safety. The restraint must be stored and the selector switch (on the control box) returned to the restraint stored position after the loading/unloading process is complete.

Installation

These installation instructions were written to guide you during the installation process. Please read and familiarize yourself with all sections of this manual prior to starting the installation. If you have any questions about the installation or operation of the Poweramp mechanical truck restraint, please consult the factory at (414) 255-1510 before proceeding.

Open and inspect all material upon delivery. Check contents against packing slip. Report any damage or shortages immediately to the truck line responsible.

Gather all material required for installation of restraint.

Available for purchase with the restraint are: Wall Anchor kit Part #2103-0003 or Ground Anchor Kit #2103-0006.

Spare parts are listed below.

Item	Qty.	Part #	Description
1	2	2101-0174	Rod 1" - 8UNL GR5 x 12
2	2	2101-0175	Nut 1" - 8UNL GR5
3	6	2101-0108	Anchor 5/8" x 5"
4	2	2101-0086	Washer

Additional material required to complete the restraint installation not supplied by Poweramp consist of the following:

Item	Qty.	Part #	Description
1	1	2101-0177	Adhesive cartridge Rawl# 8403
2	1	2101-0178	Nozzle Rawl# 7908
3	1	2101-0179	Injection tool Rawl# 8406
4	1	N/A	1" nylon bottle brush

Items listed above with Poweramp part numbers may be purchased separately. Each adhesive cartridge should be adequate to install three restraints. Nozzles are not reusable.

1. Correct installation of the Poweramp mechanical truck restraint requires attachment to a concrete drive greater than 6" thick. If other conditions exist, such as asphalt, a 48" wide by 48" long x 8" deep pad using a minimum of 4000 psi concrete must be poured.
2. Because of the restraint's unique design, its mounting location is referenced off the bumper face. This insures its compatibility with almost all dock designs. Properly installed bumpers, in good repair, are essential to a safe dock. If inspection of bumpers shows them to be missing, damaged or severely worn, contact your Poweramp representative to obtain replacements.
3. Position the Poweramp mechanical truck restraint in the center of the dock/door opening with the primary (1") anchor holes located 1/2" ahead of the bumper face as shown in Figure 7. After locating and marking the primary anchor locations (qty. 2) on the drive surface, drill 1-1/8" diameter holes 8-8-1/2" deep. If drill breaks through concrete at a depth of less than 6", consult factory. The remaining (6) 3/4" anchor holes can be drilled at this time.

Installation

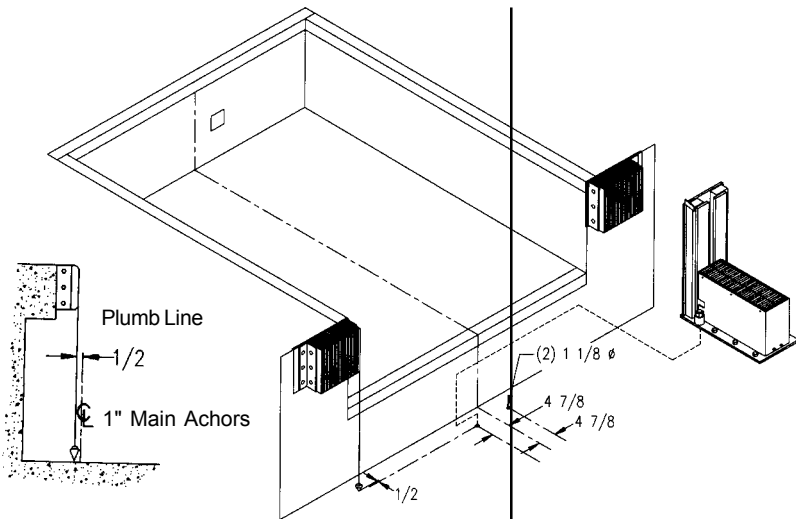

Figure 7

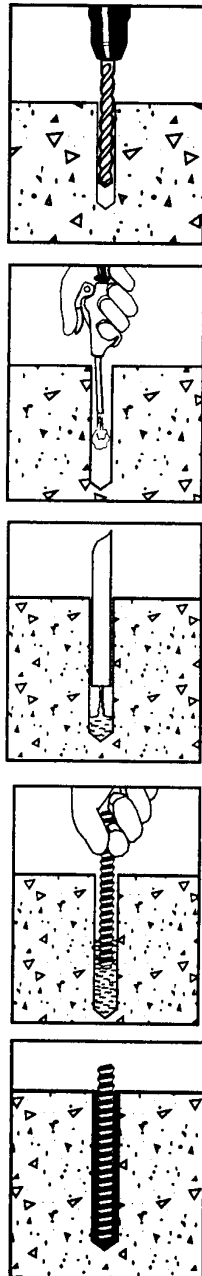

Figure 8

4. Preparation of the anchor hole is necessary to assure a long lasting installation. Prepare the 1-1/8" diameter holes in the following manner:

- A. Blow the hole clean with compressed air, brush out using 1" nylon brush, blow clean again. Holes should be clean and sound. They may be dry or damp, but should be free of standing water or frost. Be sure rod fits into hole. If larger hole is required, the diameter should be as close as possible to the rod diameter.
- B. Fill the hole approximately half way with adhesive mortar starting from the rear of the hole. Slowly withdraw the nozzle as the hole fills to avoid creating air pockets within the hole.
- C. Push the threaded rod into the hole while turning slightly to insure positive distribution of the adhesive mortar. Be sure rod is fully seated at the bottom of the hole and that the mortar has flowed from the top of the hole. If an insufficient amount of adhesive is placed in the hole, indicated by a lack of filling to the top of the hole when the rod is inserted, the rod must be extracted, additional adhesive added and rod reinserted. The threaded rod used must be free of dirt, grease, oil or other foreign material. Allow the adhesive mortar to cure for the time specified in chart prior to applying any load. See Figure 10. Do not distribute or load the anchor until it is fully cured.

Handling can be simplified and line up insured if restraint is positioned over holes before rods are inserted for the final time. After adhesive has cured, adjust restraint using a bubble level, so the back is perpendicular. Shim under bottom as needed.

Install remaining six anchors using the following procedure:

Installation

Using the proper diameter bit, drill a hole into the base material to a depth of at least 1/2" or one anchor diameter deeper than the embedment required. The tolerances of the drill bit used should meet ANSI Standard B94.12.

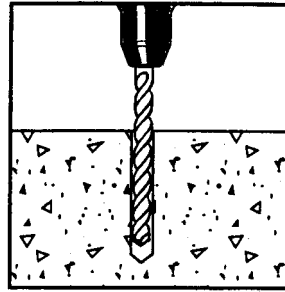

Blow the hole clean of dust and other material. Remove the inspection tag from the anchor and position the fixture. Do not expand the anchor prior to installation.

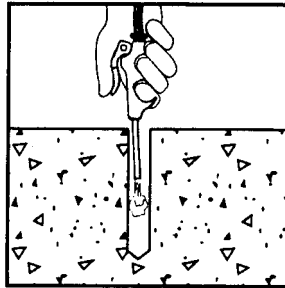

Drive the anchor through the fixture into the anchor hole until the bolt head is firmly seated against the fixture. Be sure the anchor is driven to the required embedment depth.

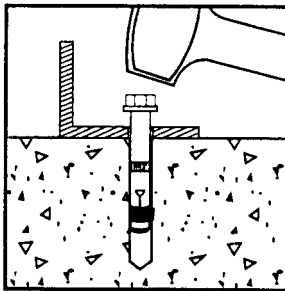

Tighten the anchor by turning the head 3 to 4 turns.

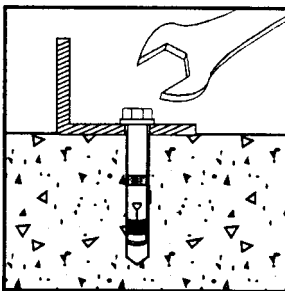

Figure 9

Base Material Temp.(F°)		Maximum Gel Time (minutes)		Minimum Curing Time (hours)		Full Curing Time (hours)	
Fast Set	Slow Set	Fast Set	Slow Set	Fast Set	Slow Set	Fast Set	Slow Set
40	40	30	60	8	16	36	48
60	60	20	45	3	7	24	36
75	75	15	35	2	6	24	24
90	90	10	20	1-1/2	4	16	24

Do not install in base material whose temperature is less than 40°F. unless job site testing is performed.

Figure 10

If your mechanical restraint is equipped with a Dock alert light communication package, please continue to follow the installation instructions. If your unit is not equipped with lights, please turn to the operation section, page 9.

INSTALLATION OF ELECTRICAL COMPONENTS

When equipped with a light communication package, the mechanical restraint includes a prewired control box, outside light box, and (2) outside truck driver signs. Components such as conduit, fittings, anchors, etc. are supplied by others. Quality workmanship using materials approved by code is required.

A typical installation will require mounting of the outside light box as shown in Figure 11. The control box mounting is generally inside the building on the left hand side of the overhead door.

Flexible conduit supplied with the mechanical restraint must be connected to a junction box (supplied by others). The location of the junction box may vary. Whenever possible, the junction box should be placed high on the outside wall or on the pit floor to avoid flooding. The junction box and associated conduit are to be supplied by others. Wiring to and from the restraint must be limited to restraint wiring only. Do not run high voltage lines through the same conduit as restraint wires.

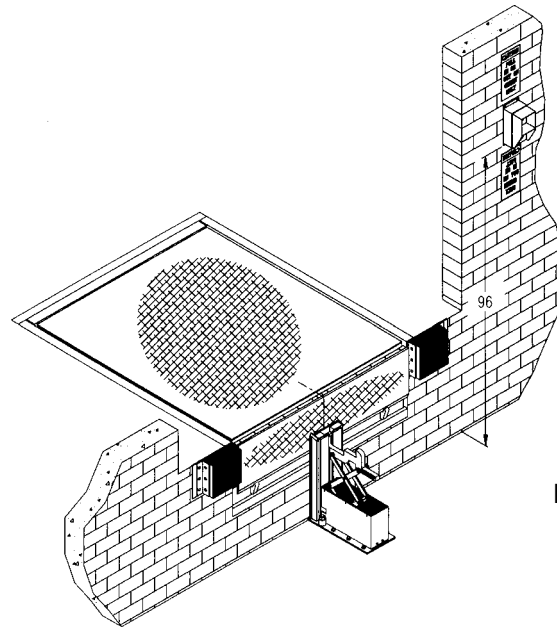

Figure 11

INSTALLATION OF SIGN

Because of the many ways signs can be mounted, hardware is not supplied. Mount the sign(s) on the right hand side, as viewed by truck driver, of restraint. The sign is usually mounted near the outside signal light permitting the truck driver to read signs from truck.

Figure 11 provides a suggested location for sign mounting. Good workmanship and quality materials should be used.

NOTES:

1. Some docks may have dock/truck seals (or shelters) installed or planned. Sign location and mounting should be studied before proceeding.
2. If required, signs may be trimmed for fit. **NEVER** cut or eliminate sign letters/ words.

Operation

The Poweramp mechanical truck restraint was designed to work in conjunction with other dock equipment allowing the dock attendant to create a safer working environment.

Before operating the equipment, be sure the rear of the trailer has been parked tight against the face of both dock bumpers. If your loading dock is equipped with a dock leveler, the hinged lip must be in the pendant, stored position prior to operating the restraint.

Operation of the restraint will vary slightly depending on whether your restraint is equipped with a light communication package. Always operate the truck restraint from atop the dock using the operating bar provided to prevent personal injury.

Prior to operating the equipment for the first time, check to see if the installers moved the release lever shipping bolt to the operating position. The release lever shipping bolt is located directly above the release lever. Failure to move this bolt will result in a non-operational restraint.

OPERATION WITH AUTOMATIC LIGHTS

The following procedure can be used for operating Poweramp mechanical restraints equipped with automatic lights.

1. Verify that the light control switch is in the automatic position, and that a red light is illuminated inside with a green light illuminated outside.
2. Verify that the trailer is parked tight against both bumpers.
3. Insert one end of the operating bar under the release lever on the left hand side of the restraint.
4. Lift up on the operating bar, causing the release lever to rotate, thus activating the restraint. With the restraint activated, the restraint arm will move vertically.
5. Visually inspect and confirm that the truck restraint arm has travelled vertically and has engaged the horizontal member of the ICC bar. Visually verify that the outside light has switched to red and that the activated light inside is illuminated.
6. Return operating bar to its storage bracket.
7. Activate dock leveler and proceed to load/unload.
8. When loading/unloading of truck is completed, return the dock leveler to the stored position.
9. Insert operating bar into the top of the slide track on the truck restraint.
10. Push the restraint arm down until the release lever locks on the carriage body.
11. Verify that the inside light has changed and that the stored light is now illuminated.
12. Return the operating bar to the storage rack.

OPERATION WITH MANUAL LIGHTS

1. Switch the inside control box light control switch to the released position. Verify that the green light has illuminated.
2. Verify that the trailer is parked tight against both bumpers.
3. Insert one end of the operating bar under the release lever on the left hand side of the restraint.
4. Lift up on the operating bar, causing the release lever to rotate, thus activating the restraint. With the restraint activated, the restraint arm will move vertically.
5. Visually inspect and confirm that the truck restraint arm has travelled vertically and has engaged the horizontal member of the ICC bar. Visually verify that the outside light has switched to red and that the activated light inside is illuminated.
6. Return operating bar to its storage bracket.
7. Activate dock leveler and proceed to load/unload.
8. When loading/unloading of truck is completed, return the dock leveler to the stored position.
9. Insert operating bar into the top of the slide track on the truck restraint.
10. Push the restraint arm down until the release lever locks on the carriage body.
11. Switch the inside control box light control switch to the stored position. Verify that the red light has illuminated.

OPERATION WITHOUT LIGHTS

1. Verify that the trailer is parked tight against both bumpers.
2. Insert one end of the operating bar under the release lever on the left hand side of the restraint.
3. Lift up on the operating bar, causing the release lever to rotate, thus activating the restraint. With the restraint activated, the restraint arm will move vertically.
4. Visually inspect and confirm that the truck restraint arm has travelled vertically and has engaged the horizontal member of the ICC bar.
5. Return operating bar to its storage bracket.
6. Activate dock leveler and proceed to load/unload.
7. When loading/unloading of truck is completed, return the dock leveler to the stored position.
8. Insert operating bar into the top of the slide track on the truck restraint.
9. Push the restraint arm down until the release lever locks on the carriage body.
10. Return the operating bar to the storage rack.

Maintenance/Troubleshooting

MAINTENANCE

1. Good housekeeping practice is the most commonly needed truck restraint requirement. Shipping and receiving docks are notorious for having wood scraps, steel banding and other debris laying at the front of the dock. Daily patrol truck restraint area and clean up dock.
2. Depending on the type of application, the truck restraints usually require lubrication every three months. Lubricate back track with an anti-seize lubricant. Lubricate linkage with 30 wt. oil.
3. **IMPORTANT:** Inspect daily and test the inside and outside signal lights. **THEY MUST WORK.** Replace broken light/bulb as required.
4. Repair or replace signs if required.
5. **IMPORTANT:** Truck restraint must be protected by dock bumpers. Worn, torn, loose or missing bumpers must be replaced. Contact your local representative for replacement bumpers.
6. Perform operation/test after all repairs and adjustments.

TROUBLESHOOTING

WARNING: Do not allow personnel or materials in operating path of restraint when carriage is in stored position. When released, carriage raises at a sufficient velocity to cause severe injury. Perform service with unit raised.

1. If carriage will not raise:
 - A. Check side release lever--it may be bound and not releasing.
 - B. Check restraint body for debris which may bind operation.
 - C. Check for broken lifting springs.
 - D. Check link joints for missing or bent shoulder bolts, pins or excessive wear.
 - E. Joints are permanently lubricated bushings and should not require oiling. However, rubbing surfaces of links should be lubricated per maintenance section of this manual.
2. If carriage will not lower or lock down:
 - A. Check side release lever--it may be bound and not engaging.
 - B. Check restraint body for debris which may bind operation.
 - C. Check link joints for missing or bent shoulder bolts, pins or excessive wear.
 - D. Joints are permanently lubricated bushings and should not require oiling. However, rubbing surfaces of links should be lubricated per maintenance section of this manual.
 - E. On occasion, the truck may move forward, trapping the ICC bumper maintaining a positive engagement. To unlock the restraint carriage, it may be necessary for the truck to back up.

Maintenance/Troubleshooting

3. If signal lights, either inside or outside, fail to operate or operate incorrectly:
NOTE: Both sets of lights are controlled from the same control box switch.
 - A. Check bulbs. Replace as required.
 - B. Check on/off switch. Repair or replace if needed.
 - C. Check electrical power source.
4. If restraint is equipped with automatic light control and lights do not change properly, test relay in control box and proximity switch on restraint for proper operation.

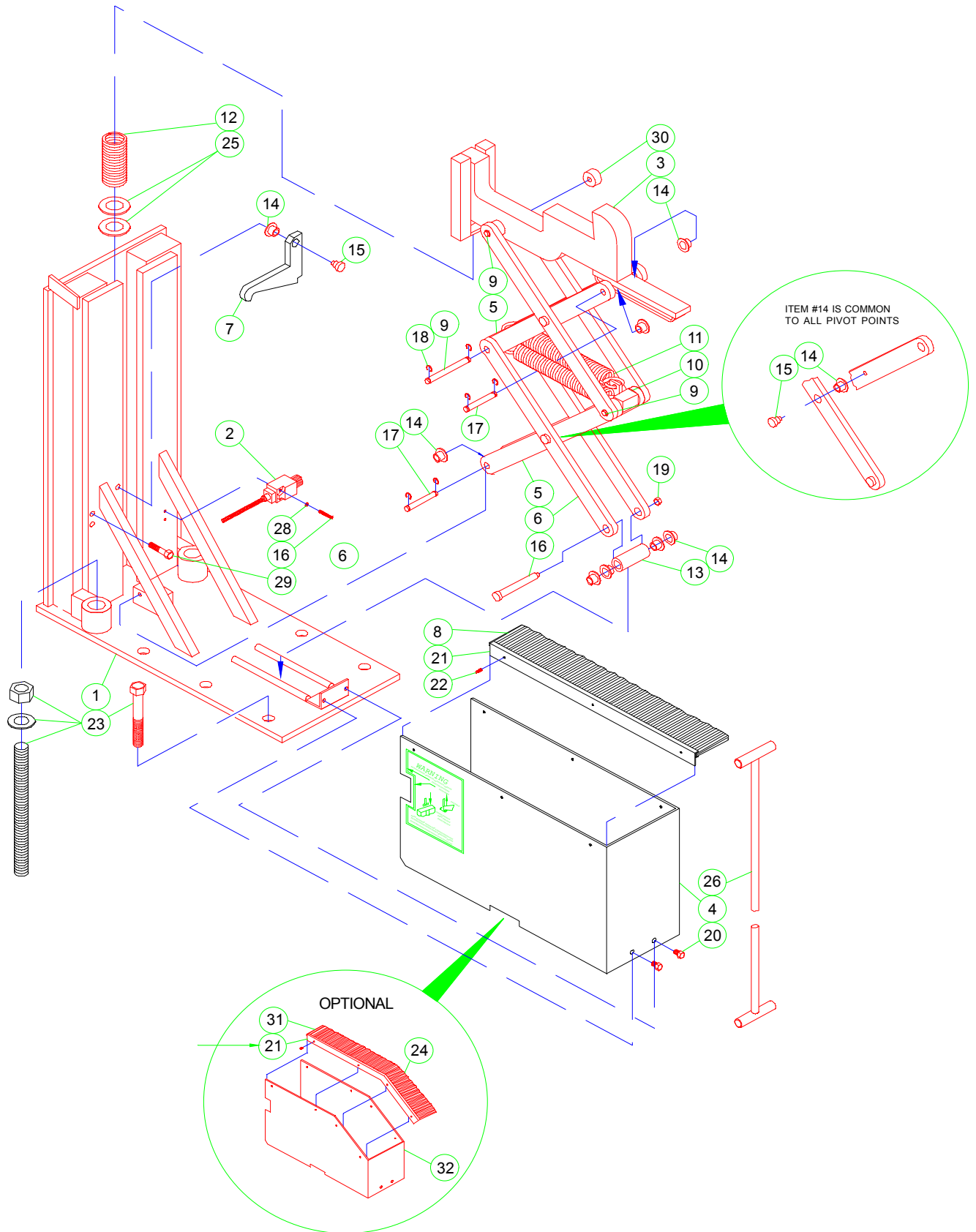

Figure 12

BILL OF MATERIALS

ITEM	QTY	PART NUMBER	DESCRIPTION
1	1	9414-0034	BASE WELDMENT
*2	1	0961-0148	PROXIMITY SWITCH
3	1	9413-0049	RESTRAINT WELDMENT
4	1	9411-0023	SHROUD
5	4	9412-0148	BAR LINK - TAPPED CENTER
6	4	9412-0149	BAR LINK
7	1	9412-0180	RELEASE LEVER
8	2	0192-0053	BRUSH - WEATHERSEAL
9	3	9202-0042	PIN - LONG
10	2	9413-0044	SPRING PLATE WELDMENT
11	2	0941-0011	SPRING EXTENSION
12	1	0522-0002	SPRING - RESTRAINT GUIDE
13	1	9412-0160	ROLLER
14	21	9461-0006	FLANGED SHOULDER BEARING - BRONZE
15	5	2101-0165	SOCKET HEAD SHOULDER SCREW
*16	2	2101-0182	PHILLIPS SCREW = #8 X 1-1/4
17	2	9202-0043	PIN - SHORT
18	10	2101-0189	E CLIP
19	1	2101-0039	HEX HEAD NUT
20	2	2101-0057	HEX HEAD CAPSCREW
21	2	0192-0052	TRACK - WEATHERSEAL
22	6-8	2101-0180	SCREW - PHILIPS
23	1	2103-0001	ANCHOR KIT
*24	2	0192-0056	BRUSH WEATHERSEAL - OPTIONAL
25	2-3	2101-0085	FLAT WASHER
26	1	5455-0005	OPERATING LEVER
27	1	2101-0181	SOCKET HEAD SHOULDER SCREW
*28	2	2101-0156	LOCK WASHER - #8
29	1	2101-0018	HEX HEAD CAP SCREW
30	2	9412-0161	BOSS
*31	2	2101-0189	BRUSH WEATHERSEAL - OPTIONAL
*32	1	9411-0025	SHROUD - TAPERED - OPTIONAL

* OPTIONAL:

1. ITEM #2, 16 & 28 IS ADDED
2. ITEM #24, 31 & 32 REPLACES ITEM #4 & 8
ITEM #22 QUANTITY CHANGES FROM 6 TO 8

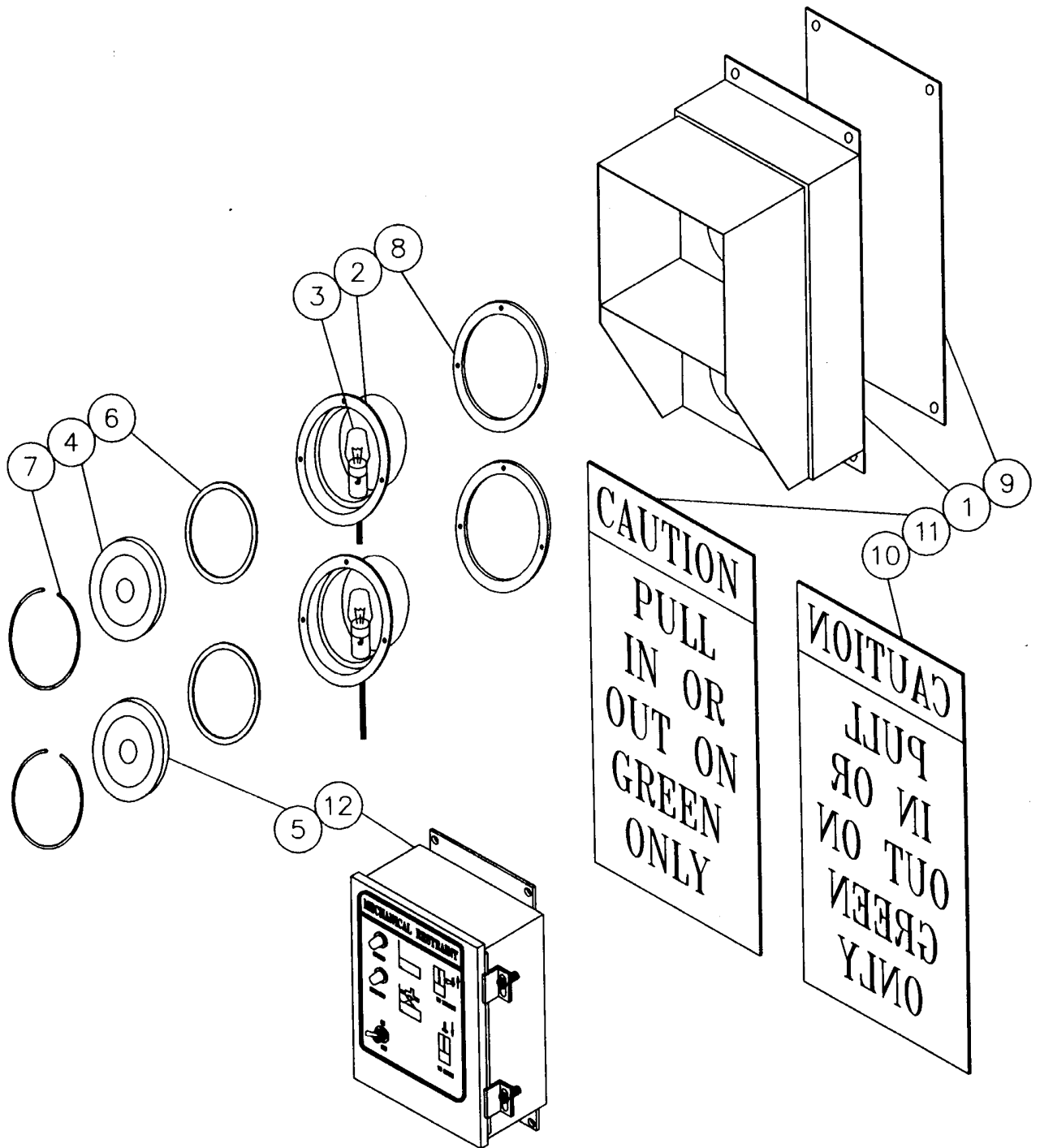

Figure 13

BILL OF MATERIALS

ITEM	QTY.	PART NUMBER	DESCRIPTION
1	1	7154-0002	SIGNAL LIGHT HOUSING ASSY.
2	2	7153-0006	LIGHT ASSEMBLY
3	2	3051-0046	LAMP (GE 10C7DC)
4	1	7151-0002	RED LENS
5	1	7151-0003	GREEN LENS
6	2	7151-0026	LENS GASKET
7	2	7151-0011	SNAP RING
8	2	7151-0006	LIGHT ASSEMBLY GASKET
9	1	7152-0006	BACK PLATE
10	1	1751-0034	CAUTION SIGN - MIRRORED
11	1	1751-0033	CAUTION SIGN
12	1	2751-0125	CONTROL BOX

SYSTEMS, INC. WARRANTY

Powerstop Vehicle Restraint

Systems, Inc. guarantees the materials, components, and workmanship in your Poweramp POWERSTOP to be of the highest quality and to be free of defects in material and workmanship for a period of one (1) year from date of shipment.

Systems, Inc. further guarantees the hydraulic components on all Poweramp POWERSTOP for a period of one (1) year from date of shipment. The electrical components carry a one (1) year warranty (lights not included).

In the event of any defect covered by this guarantee, Systems, Inc. will remedy said defect by repairing or replacing all defective parts, bearing all of the costs for parts, labor and transportation.

All guarantee claims will be settled on a timely basis when defects are found to be from other than improper installation, operating contrary to instructions or beyond rated load capacities, abuse, careless or negligent use, or failure to maintain the unit as recommended by the owner's manual.

There are no guarantees, either expressed or implied, including any implied guarantees of merchantability or fitness for a particular purpose which shall extend beyond the guarantee periods indicated above. This guarantee is valid only if the unit(s) is unaltered from original condition as delivered from the factory and a survey is completed by a Poweramp representative.



W194 N11481McCormick Drive – PO Box 309 - Germantown, WI 53022
Phone 800-643-5424
Fax: 262-255-4199
www.docksystemsinc.com