

## AUTOMATIC VEHICLE RESTRAINT



\* Integrated controls and PowerHook® KS6 shown engaged on trailer's Rear Impact Guard (RIG).

- ▶ Push Button Activation
- ▶ iDock® Controls with Interactive Message Display
- ▶ iDock Controls Connected Online with Optional myQ Dock Management
- ▶ Restraining Force in Excess of 35,000 lbs.
- ▶ Recessed Design - For Unobtrusive Access
- ▶ Positive Restraining Force Eliminates "Trailer Creep"
- ▶ Operational Range: 0" to 15" Horizontally; 7" min to 34" Vertically
- ▶ Automatic Re-Store Feature
- ▶ Custom PCV Solid State Control
- ▶ Amber Light - Caution Indicator
- ▶ Diagnostic - Fault Indicator Light
- ▶ Bypass/Override Passcode
- ▶ Exterior Light Emphasizer Upon Early Truck Departure
- ▶ Made in the USA

## Structurally Superior by Design

There are many components that insure a safe material handling operation. The most important, however, is an effective, dependable truck restraining system like the PowerHook® from Poweramp.

The PowerHook vehicle restraint is a premier restraining device that seeks, finds, and secures a trailer's "Rear Impact Guard" (RIG). The PowerHook maintains constant contact on the RIG during the loading and unloading operation. It's programmed to operate on both the longitudinal (x) and the vertical (y) axis to prevent any gap between the restraint and the trailers RIG, eliminating "trailer creep" and loss of leveler lip purchase.

The PowerHook is controlled by the most advanced electronics in the industry. This sophisticated system is not only pre-programmed to perform all standard functions quickly and effectively, but can also be customized to combine any existing security and energy conservation systems, resulting in increased convenience and efficiency. All control panels are designed, manufactured and tested in Poweramp's UL-approved facility to insure proper operation.

The PowerHook restraint is firmly anchored in the loading dock pit for maximum holding strength. The hook remains protected behind the pit wall until activated. The restraint is designed to withstand a pulling force in excess of 35,000 lbs, giving you an extra margin of safety and protection. The PowerHook has the widest service

ranges in the industry with a horizontal range of 0" to 15" from the building and a vertical range from 7" to 34" off the drive. Extended ranges are available for special applications.

The PowerHook has historically been proven to operate efficiently! With over 15,000 applications over a 30 year period, the durability and reliability of the PowerHook is unmatched in the industry. Be sure to specify the "original" PowerHook on your next loading dock application.



## Lower your Initial Building Costs with CentraPower®



If your business requires six or more dock levelers, you can reduce the expense of operating and maintaining multiple individual pumping stations by using a single hydraulic source, CentraPower® System by Poweramp.

CentraPower is an easy to install, cost-effective, multi-leveler remote system. CentraPower consolidates the individual electric motors, pumps and reservoirs of several standard levelers into one convenient hydraulic pump station. The reduction of "home run" electrical runs, disconnects and control wiring can produce significant initial cost savings while simplifying maintenance requirements. Additional system assurances are afforded as CentraPower comes standard with a back-up motor and pump assembly for complete peace of mind.

# POWERHOOK® VEHICLE RESTRAINT

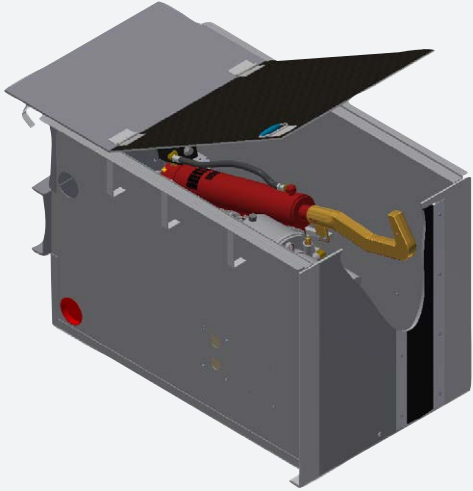

The **PowerHook® KS4** box-type vehicle restraint is ideally suited for Vertical Leveler installations. The larger box form with insulated lid is fully assembled and ready to be poured in place during the construction process.

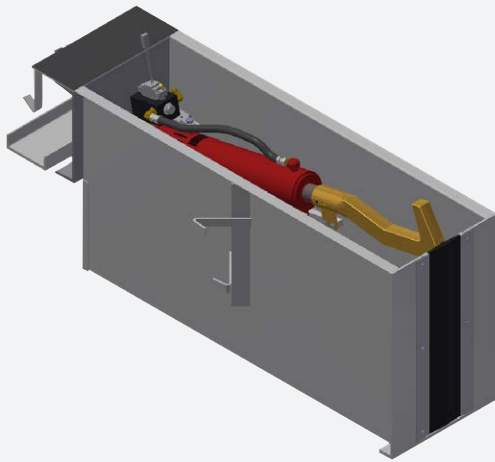

The **PowerHook® KS5** pan-type vehicle restraint is an economical retrofit for dock levelers. The fully assembled pan ships complete with all the concrete anchors needed to ensure a secure installation.

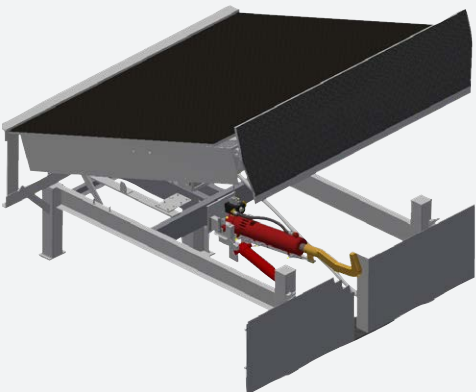

The **PowerHook® KS6** free-standing frame type vehicle restraint is fully installed and integrated into full height leveler stand. It's easy to install...just weld it into position and run power to it.





The PowerHook seeks, finds, and secures a trailer's RIG to the dock.

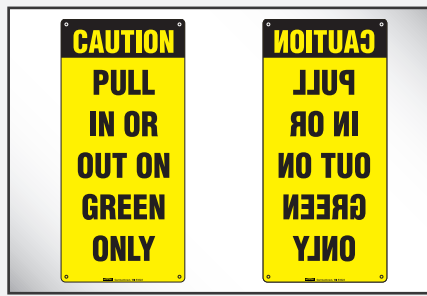

A set of standard and mirrored image caution signs notifies the truck driver.



iDock® Controls includes light communication and can be integrated with other dock equipment.

### VEHICLE RESTRAINT SYSTEM

The PowerHook® is a non-impact, self-aligning, hydraulic vehicle restraint and is available as a standalone unit or integrated with other loading dock equipment through an optional integrated control panel. The unit is stored in the dock pit and helps prevent unexpected trailer departure from the loading dock during the loading/unloading process.

### OPERATION

Once a trailer is backed into position against the dock bumpers, the operator presses the "Engage" button, activating the PowerHook to extend out and up to seek the trailer's Rear Impact Guard (RIG). The restraint then applies continuous pressure to the RIG to securely hold the trailer to the dock. After loading is complete, the operator presses the "Release" button, lowering the hook and retracting it to a safely stored position in the dock pit, releasing the trailer.

### SAFETY FEATURES

- Positive hydraulic retention of RIG for zero running room.
- Stored in the dock pit and out of the way while not in use.
- Amber caution light when restraint is in process of engaging RIG or in override conditions.
- Integrated iDock Controls for safe leveler interlock.
- Full communication package with signage and interior/exterior red/green lights in opposing mode.
- Red exterior light flashes rapidly when pullout force is applied to the hook.
- Restraining force in excess of 35,000 lbs.

### ADVANCED COMMUNICATION

The PowerHook restraint uses advanced iDock Controls with an LED 3-color light communication system. As a truck approaches, the exterior light is green and the interior light is red. Once the trailer is in position and the PowerHook is activated, the exterior light will change to red, warning the driver not to pull away, and interior light to amber while the restraint is in motion and green once the trailer is secured, allowing the dock attendant to safely enter the trailer. When the trailer is released and the restraint is safely stored, the interior light reverts back to red and the exterior light changes back to green.

If the PowerHook is unable to secure the trailer's RIG due to abnormal trailer conditions, the restraint will communicate the fault condition by illuminating an amber "Caution" light on the iDock Controls, or by an optional audible alarm. If "By-Pass" of the system is necessary, it is recommended that you secure the trailer by other means before proceeding with the loading/unloading process. In "By-Pass" mode the exterior light is red and the interior light is green, accompanied by the amber caution light indicating to the dock attendant to proceed with caution.



W194 N11481 McCormick Drive • Germantown, WI 53022  
Phone: 1.800.643.5424 • Email: sales@poweramp.com

[www.Poweramp.com](http://www.Poweramp.com)

### HYDRAULICS & ELECTRICAL

The restraint utilizes hydraulic cylinders that allow the PowerHook restraint to securely engage and hold a trailer's RIG. The pump and motor is available in a single or three phase, as well as various voltage options. The control panel is NEMA 4X with all components, connections and wiring UL listed and/or recognized. Panels are built in Poweramp's UL-approved control panel shop.

### CONSTRUCTION

With a zinc-plated hook and hardware, the PowerHook is typically mounted in a fabricated pan assembly positioned under the dock leveler that is integrated and anchored to the concrete construction of the building. This assembly can also be mounted to a freestanding dock leveler frame. The hydraulic components can be remote mounted or integrated with the dock leveler.

PowerHook® Series Common Options	
▶	Integrated control panel
▶	Custom interlock sequence with leveler
▶	Audible alarm
▶	Extended hook range
▶	Self-contained unit
▶	Remote power pack
▶	Centrapower® - Multiple units on single power source
▶	Spray metallized or galvanized steel embed

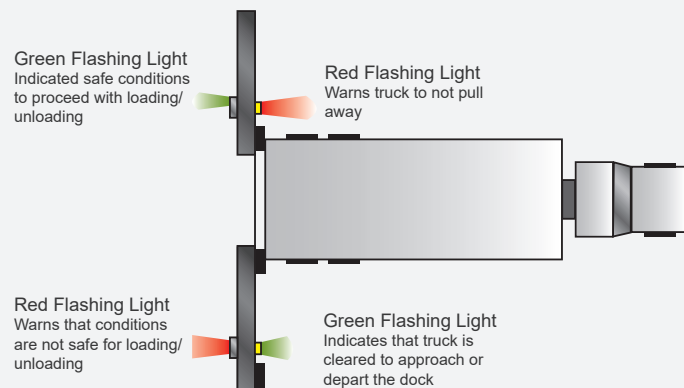

Connect online with

myQ®  
DOCK MANAGEMENT