

A Division of Systems, LLC

**POWERAMP**<sup>®</sup>

Premium Loading Dock Systems

**Mini Ramp**

Dock Leveler

**Owner's/User's Manual**



**Poweramp** • Division of Systems, LLC • W194 N11481 McCormick Drive • Germantown, WI 53022

800.643.5424 • fax: 262.255.5917 • [www.poweramp.com](http://www.poweramp.com) • [techservices@poweramp.com](mailto:techservices@poweramp.com)

Printed in U.S.A.

© 2020 Systems, LLC - All Rights Reserved

Manual No. 4111-0083

Apr. 2020

# Table Of Contents

	Page
<b>Precautions</b>	
Recognize Precautionary Information .....	1
General Operational Precautions .....	1
Operational Precautions .....	2
Safety Decals.....	4
Placard .....	5
Owner's/User's Responsibilities.....	6
<b>Introduction</b>	
General Information.....	8
Component Identification.....	9
<b>Installation</b>	
Installation Precautions .....	10
Prepare Pit.....	12
Install Dock Leveler .....	14
Install Control Panel and Wiring .....	20
Placard Installation Instructions .....	21
Put New Dock Leveler Into Service.....	22
<b>Operation</b>	
Operational Precautions .....	23
Ramp Loading/Unloading Instructions.....	24
End Loading/Unloading Instructions .....	25
Optional Equipment.....	26
<b>Maintenance</b>	
Maintenance Precautions.....	27
Periodic Maintenance .....	28
<b>Adjustments</b>	
Adjust Main Pressure Relief .....	30
Adjust Cable Weight and Down Speed Control.....	31
Adjust Auto Return To Dock (ARTD) .....	32
<b>Troubleshooting</b>	
Troubleshooting.....	36
<b>Parts</b>	
Electrical Parts .....	40
Frame and Platform .....	42
Hydraulic Components.....	44
Platform Cylinder Repair Parts.....	46
Lip Cylinder Repair Parts.....	47
Logic Block Assembly .....	48
Valve Blocks .....	50
Power Pack Assembly .....	52
<b>Miscellaneous</b>	
Customer Information .....	57
Warranty.....	Back Cover

# PRECAUTIONS

## Recognize Precautionary Information

### Safety-Alert Symbol



The Safety-Alert Symbol is a graphic representation intended to convey a safety message without the use of words. When you see this symbol, be alert to the possibility of death or serious injury. Follow the instructions in the safety message panel.

### **DANGER**

The use of the word DANGER signifies the presence of an extreme hazard or unsafe practice which will most likely result in death or severe injury.

### **WARNING**

The use of the word WARNING signifies the presence of a serious hazard or unsafe practice which could result in death or serious injury.

### **CAUTION**

The use of the word CAUTION signifies possible hazard or unsafe practice which could result in minor or moderate injury.

### **NOTICE**

The use of the word NOTICE indicates information considered important, but not hazard-related, to prevent machine or property damage.

## SAFETY INSTRUCTIONS

Indicates a type of safety sign, or separate panel on a safety sign, where safety-related instructions or procedures are described.

## General Operational Precautions



Read and understand the Owner's/User's Manual and become thoroughly familiar with the equipment and its controls before operating the dock leveler.

Never operate a dock leveler while a safety device or guard is removed or disconnected.

Never remove DANGER, WARNING, or CAUTION signs, Placards or Decals on the equipment unless replacing them.

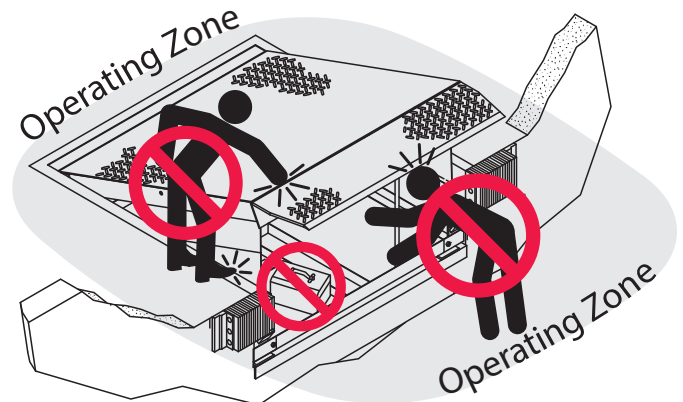

Figure 1

Do not start the equipment until all unauthorized personnel in the area have been warned and have moved outside the operating zone (see Figure 1).

Remove any tools or foreign objects from the operating zone before starting.

Keep the operating zone free of obstacles that could cause a person to trip or fall.



**WARNING:** This product can expose you to chemicals including lead, which are known to the State of California to cause cancer or birth defects or other reproductive harm. For more information go to [www.P65Warnings.ca.gov](http://www.P65Warnings.ca.gov)

# PRECAUTIONS

## Operational Precautions



Learn the safe way to operate this equipment. Read and understand the manufacturer's instructions. If you have any questions, ask your supervisor.

### **DANGER**



Stay clear of dock leveling device when transport vehicle is entering or leaving area.



Do not move or use the dock leveling device if anyone is under or in front of it.

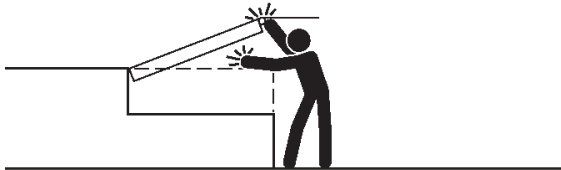

Keep hands and feet clear of pinch points. Avoid putting any part of your body near moving parts.

### **WARNING**



Chock/restrain all transport vehicles. Never remove the wheel chocks or release the restraining device until loading or unloading is finished, and transport driver has been given permission to drive away.



Do not use a broken or damaged dock leveling device or restraining device. Make sure proper service and maintenance procedures have been performed before using.



Make sure lip overlaps onto transport vehicle bed at least 4 in. (102 mm).



Keep a safe distance from both side edges.

Operational Precautions

**! WARNING**

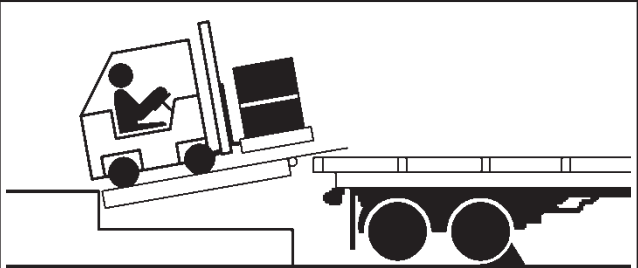

Do not use dock leveling device if transport vehicle is too high or too low.

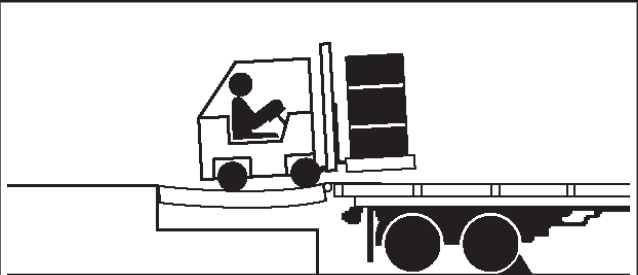

Do not overload the dock leveling device.



Do not operate any equipment while under the influence of alcohol or drugs.

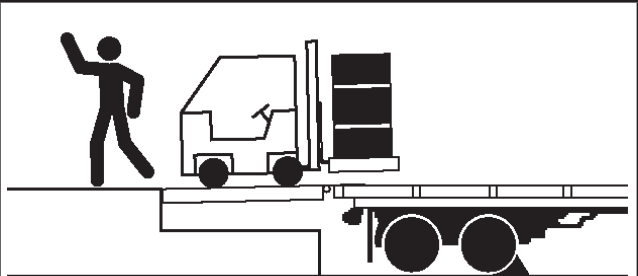

Do not leave equipment or material unattended on dock leveling device.

# PRECAUTIONS

## Safety Decals



1751-0329



1751-0735



1751-0330 Two positions on the back frame of the unit.

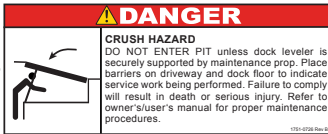

1751-0726

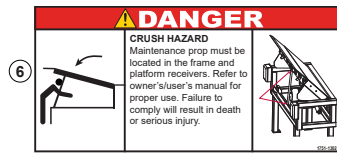

1751-1302

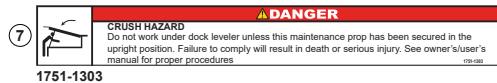

1751-1303



1751-0138

**⚠ DANGER**

Unsupported dock leveler ramps can lower unexpectedly.

Before allowing vehicle to leave the dock always:

- Ensure no equipment, material or people are on dock leveler.
- Return dock leveler to its stored position at dock level.

Failure to follow posted instructions will result in death or serious injury.

**SAFETY INFORMATION**

**PRECAUTIONS**

Read and follow all instructions and warnings in owner's user manual. Call if dock leveler malfunctions to trained operator.

Always check trailer wheels on engage. Truck restraint before opening dock leveler or engaging to load or unload.

Never use hands or equipment to move ramp up.

Follow unloading dock leveler:

- Check trailer alignment to avoid tire interference if it does not retract.
- Check trailer alignment to avoid tire interference if it does not retract.
- Ensure track bed supports extended lip or leveler frame supports the ramp before driving on ramp.

**MAINTENANCE/SERVICE**

Read and follow all instructions, warnings and maintenance schedule in the owner's user manual.

Maintenance/service of dock leveler restricted to trained personnel.

Place barriers on the driveway and dock floor to indicate service work is being performed.

**DO NOT ENTER PIT** unless dock leveler is securely supported by maintenance prop.

If electrically powered turn off and use OSHA lockout/tagout procedures.

Call 202.225.1510 for replacement parts, wiring info, or service. [www.usa1.com](http://www.usa1.com)

4

**⚠ DANGER**

Unsupported dock leveler ramps can lower unexpectedly.

Before allowing vehicle to leave the dock always:

- Ensure no equipment, material or people are on dock leveler.
- Return dock leveler to its stored position at dock level.

Failure to follow posted instructions will result in death or serious injury.

**SAFETY INFORMATION**

**PRECAUTIONS**

Read and follow all instructions and warnings in owner's user manual. Call if dock leveler malfunctions to trained operator.

Always check trailer wheels on engage. Truck restraint before opening dock leveler or engaging to load or unload.

Never use hands or equipment to move ramp up.

Follow unloading dock leveler:

- Check trailer alignment to avoid tire interference if it does not retract.
- Check trailer alignment to avoid tire interference if it does not retract.
- Ensure track bed supports extended lip or leveler frame supports the ramp before driving on ramp.

**MAINTENANCE/SERVICE**

Read and follow all instructions, warnings and maintenance schedule in the owner's user manual.

Maintenance/service of dock leveler restricted to trained personnel.

Place barriers on the driveway and dock floor to indicate service work is being performed.

**DO NOT ENTER PIT** unless dock leveler is securely supported by maintenance prop.

If electrically powered turn off and use OSHA lockout/tagout procedures.

Call 202.225.1510 for replacement parts, wiring info, or service. [www.usa1.com](http://www.usa1.com)

4



1751-0397



1751-1304

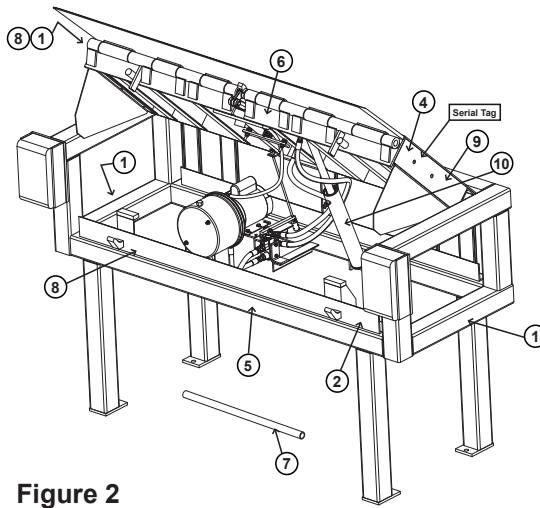



Figure 2

Decal Placement for Mini Ramp Series

## Placard



# DANGER

# OPERATING INSTRUCTIONS

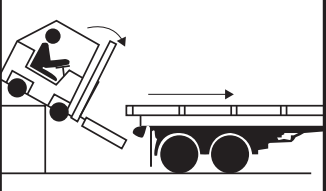

- Read and follow all instructions, warnings, and maintenance schedules in the manual and on placards.
- Operation and servicing of dock leveler is restricted to authorized personnel.

- Always chock transport vehicle wheels or engage vehicle restraint and set parking brakes before operating dock leveler or beginning to load or unload.
- Before activating dock leveler, check to make sure the transport vehicle is positioned squarely against dock bumpers. Ensure lip will avoid contact with transport vehicle frame, sides and cargo during dock leveler activation. If contact is likely or observed, reposition transport vehicle.
- Ensure the transport vehicle floor supports extended lip or the leveler frame (lip keepers or below dock endload supports) supports the ramp before driving on ramp.
- Stay clear of hinges and front and sides of moving dock leveler.
- Never use hands or equipment to move the ramp or lip.
- Never use damaged or malfunctioning dock leveler. Report problems immediately to supervisor.
- Always store dock leveler and remove people, material, and equipment from ramp before vehicle leaves the dock.
- DO NOT ENTER PIT unless dock leveler is securely supported and proper lockout/tagout procedures have been completed. See "Maintenance Precautions" in Owner's/User's Manual.

**FAILURE TO FOLLOW THESE INSTRUCTIONS WILL RESULT IN DEATH OR OTHER SERIOUS INJURY.**



Scan to view our owner's/user's manuals online.  
[www.LoadingDockSystems.com](http://www.LoadingDockSystems.com)  
**1.800.643.5424**  
 Call for additional placards, or manuals, or with questions regarding proper use, maintenance, and repair of dock leveler.



WARNING: CANCER AND REPRODUCTIVE HARM  
[www.P65Warnings.ca.gov](http://www.P65Warnings.ca.gov)

1751-0874

1751-0874 Rev D

## POWERED DOCK LEVELERS

### NORMAL OPERATION

1. Raise the platform by Pressing and holding the RAISE button.
2. Hold the RAISE button until the lip is fully extended, then release the RAISE button. The platform will lower until lip is resting on the transport vehicle.

### STORING LEVELER

1. Press the RAISE button until the lip is completely folded. When the lip is folded, release the RAISE button. The platform will lower returning to the cross-traffic position.

### BELOW DOCK ENDLOADING

- **(AIR POWERED ONLY)** Press and hold the RAISE button until the leveler is 12" above dock level. Pull the below dock level chain until the leveler lowers the full below dock position.
- **(HYDRAULIC ONLY)** Press and hold the RAISE button until the leveler is fully raised. As the lip starts to extend, release the RAISE button. The leveler will lower to the below dock position provided the lip extension allows the lip to clear the lip keepers.
- **(HYDRAULIC WITH INFINITE LIP CONTROL)** If equipped, raise the platform by Pressing and holding the RAISE button. When the lip is just above the lip keepers, simultaneously Press and hold the RAISE button and the LIP OUT button until lip has extended beyond the lip keepers. Release both buttons.

**NOTE: If equipped, Pressing E-STOP button will stop platform from lowering.**



# OWNER'S/USER'S RESPONSIBILITIES

---

- 1) The manufacturer shall provide to the initial purchaser and make the following information readily available to the owners/users and their agents, all necessary information regarding Safety Information, Operation, Installation and Safety Precautions, Recommended Initial and Periodic Inspections Procedures, Planned Maintenance Schedule, Product Specifications, Troubleshooting Guide, Parts Break Down, Warranty Information, and Manufacturers Contact Information, as well as tables to identify the grade(slope) for all variations of length or configuration of the dock leveling device and information identifying the maximum uncontrolled drop encountered when sudden removal of support while in the working range of the equipment.
- 2) When selecting loading dock safety equipment, it is important to consider not only present requirements but also future plans and any possible adverse conditions, environmental factors or usage. The owners/users shall provide application information to the manufacturer to receive recommendations on appropriate equipment specifications and capacity.
- 3) The owner/user must see all nameplates, placards, decals, instructions and posted warnings are in place and legible and shall not be obscured from the view of the operator or maintenance personnel for whom such warnings are intended for. Contact manufacturer for any replacements.
- 4) Dock leveling devices may become hazardous if the manufacturer's instructions regarding modifications or adjustments are not followed. Modifications or alterations of dock leveling devices shall only be made with prior written approval from the original manufacturer. These changes shall be in conformance with all applicable provisions of the MH30.1 standard and shall also satisfy all safety recommendations of the original equipment manufacturer of the particular application.
- 5) The owner/user should recognize the inherent dangers of the interface between the loading dock and the transport vehicle. The owner/ user should, therefore, train and instruct all operators in the safe operation and use of the loading dock equipment in accordance with manufacturer's recommendations and industry standards. Effective operator training should also focus on the owner's/user's company policies, operating conditions and the manufacturer's specific instructions provided with the dock leveling device. Maintaining, updating and retraining all operators on safe working habits and operation of the equipment, regardless of previous experience, should be done on a regular basis and should include an understanding and familiarity with all functions of the equipment. Owners/users shall actively maintain, update and retrain all operators on safe working habits and operations of the equipment.
- 6) An operator training program should consist of, but not necessarily be limited to, the following:
  - a) Select the operator carefully. Consider the physical qualifications, job attitude and aptitude.
  - b) Assure that the operator reads and fully understands the complete manufacturer's owners/users manual.
  - c) Emphasize the impact of proper operation upon the operator, other personnel, material being handled, and equipment. Cite all rules and why they are formulated.
  - d) Describe the basic fundamentals of the dock leveling device and components design as related to safety, e.g., mechanical limitation, stability, functionality, etc.
  - e) Introduce the equipment. Show the control locations and demonstrate its functions. Explain how they work when used properly and maintained as well as problems when they are used improperly.
  - f) Assure that the operator understands the capacity rating, nameplate data, placards and all precautionary information appearing on the dock leveling device.
  - g) Supervise operator practice of equipment.
  - h) Develop and administer written and practical performance tests. Evaluate progress during and at completion of the course.
  - i) Administer periodic refresher courses. These may be condensed versions of the primary course and include on-the-job operator evaluation.



# OWNER'S/USER'S RESPONSIBILITIES

---

- 7) Loading dock safety equipment should never be used outside of its vertical working range, or outside the manufacturer's rated capacity. It shall also be compatible with the loading equipment and other conditions related to dock activity. Please consult the manufacturer if you have any questions as to the use, vertical working range or capacity of the equipment. Only properly trained and authorized personnel should operate the equipment.
- 8) It is recommended that the transport vehicle is positioned as close as practical to the dock leveling device and in contact with both bumpers. When an industrial vehicle is driven on or off a transport vehicle during loading and unloading operations, the transport vehicle parking brakes shall be applied and wheel chocks or a restraining device that provides equal or better protection of wheel chocks shall be engaged. Also, whenever possible, air-ride suspension systems should have the air exhausted prior to performing said loading and unloading operations.
- 9) When goods are transferred between the loading dock and a trailer resting on its support legs/ landing gear instead of a tractor fifth wheel or converter dolly, it is recommended that an adequate stabilizing device or devices shall be utilized at the front of the trailer.
- 10) In order to be entitled to the benefits of the standard product warranty, the dock safety equipment must have been properly installed, maintained and operated in accordance with all manufacturer's recommendations and/ or specified design parameters and not otherwise have been subject to abuse, misuse, misapplication, acts of nature, overloading, unauthorized repair or modification, application in a corrosive environment or lack of maintenance. Periodic lubrication, adjustment and inspection in accordance with all manufacturers' recommendations are the sole responsibility of the owner/user.
- 11) Manufacturer's recommended maintenance and inspection of all dock leveling devices shall be performed in conformance with the following practices: A planned maintenance schedule program must be followed, only trained and authorized personnel shall be permitted to maintain, repair, adjust and inspect dock leveling devices, and only the use of original equipment manufacturer parts, manuals, maintenance instructions, labels, decals and placards or their equivalent. Written documentation of maintenance, replacement parts or damage should be kept. In the event of damage, notification to the manufacturer is required.
- 12) Loading dock devices that are structurally damaged or have experienced a sudden loss of support while under load, such as might occur when a transport vehicle is pulled out from under the dock leveling device, shall be removed from service, inspected by a manufacturer's authorized representative, and repaired or replaced as needed or recommended by the manufacturer before being placed back in service.

# INTRODUCTION

---

## General Information



**Figure 3**

This manual provides current information on the Mini Ramp-series dock leveler. Due to ongoing product improvement, some parts may have changed, along with operation and troubleshooting methods. This manual describes these changes where applicable.

The Mini Ramp-series dock leveler comes equipped with an electrical control panel, which allows push button operation of the dock leveler functions. When combining a Mini Ramp-series dock leveler with a Poweramp hydraulic vehicle restraint, the control panel will allow for operation of both units in the same control panel.

Each Mini Ramp-series dock leveler unit and control panel has been factory pre-wired and tested to ensure satisfactory operation.

To illustrate which connections are to be made in the field at installation, electrical drawings are included with each order or by contacting Systems, LLC Technical Services.

Call Poweramp to discuss available voltages, phases and options to meet your specific needs.

**Technical Service at 800-643-5424 or [techservices@loadingdocksystems.com](mailto:techservices@loadingdocksystems.com)**

## Component Identification

Inspect package and all components. Report any missing or damaged items immediately and note on the shipping Bill Of Lading (BOL).

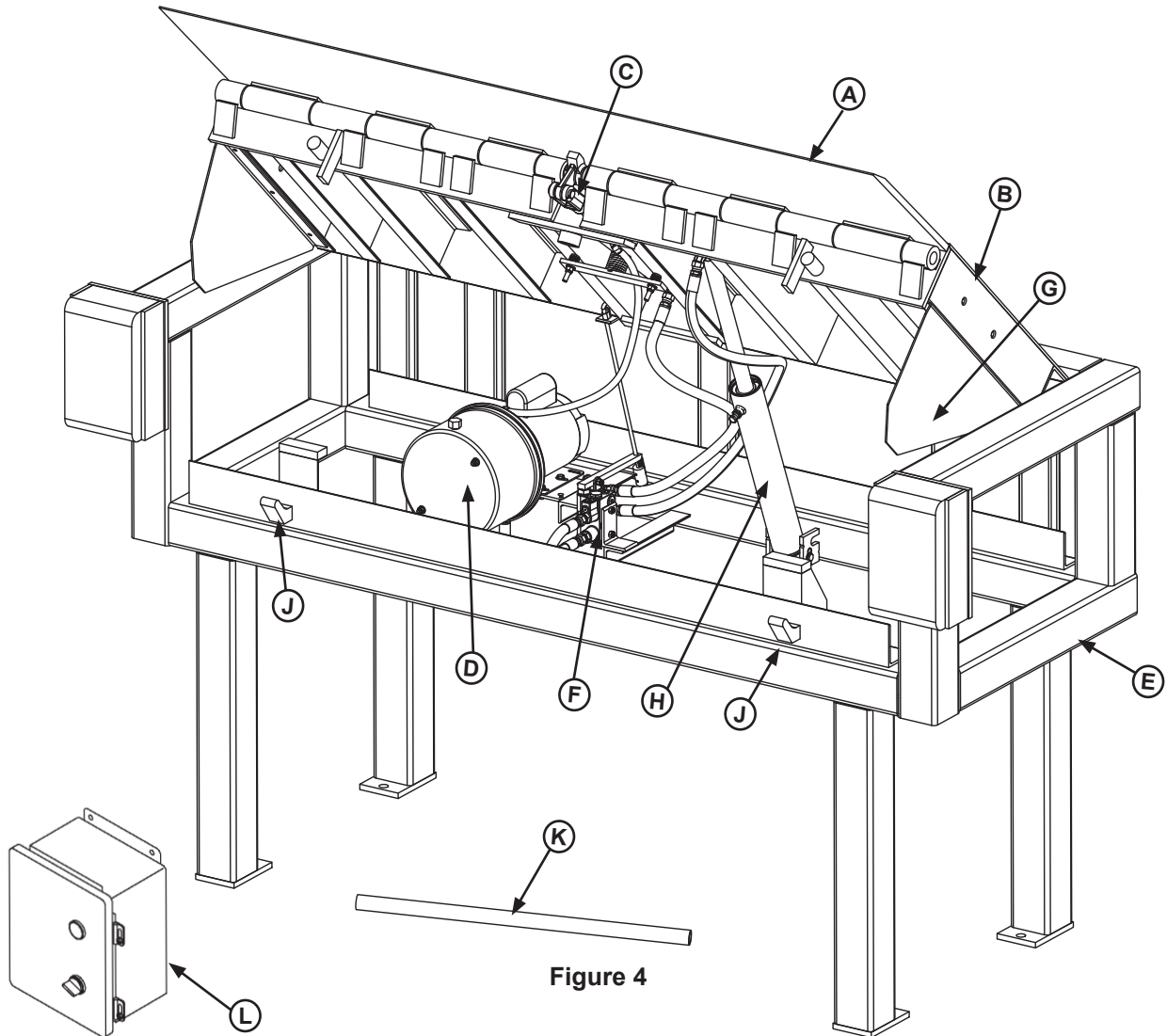

Figure 4

A — Lip  
B — Platform  
C — Lip Cylinder(s)\*

D — Powerpack (Motor/Pump/  
Reservoir)  
E — Main Frame  
F — Logic Block

G — Toe Guard (2 used)  
H — Platform Cylinder(s)\*  
J — Lip Keepers (2 used)

K — Maintenance Prop  
L — Control Box\*\*

\* Some high-capacity models are equipped with multiple cylinders.  
\*\*Control box appearance may vary depending on options.

# INSTALLATION

## Installation Precautions

### **DANGER**

It is recommended and good safety practice to use an additional means to support the dock platform and lip anytime when physically working in front of or under the dock leveler. This additional means may include, but is not limited to a boom truck, fork truck, stabilizing bar or equivalent.

### **WARNING**

Always post safety warnings and barricade the work area at dock level and ground level to prevent unauthorized use of the dock leveler before installation is complete.

A hard hat or other applicable head protection should always be worn when working under or around a dock leveler.

Always stand clear of platform lip when working in front of the dock leveler.

### **WARNING**

DO NOT grind or weld if hydraulic fluid or other flammable liquid is present on the surface to be ground or welded.

DO NOT grind or weld if uncontained hydraulic fluid or other flammable liquid is present. Stray sparks can ignite spills or leaks near the work area. Always clean up the oil leaks and spills before proceeding with grinding or welding.

Always keep a fire extinguisher of the proper type nearby when grinding or welding.

### **CAUTION**

Only trained installation professionals with the proper equipment should install this product.

### **NOTICE**

DO NOT connect the dock leveler electrical wiring and ground connections until all welding has been completed.

DO NOT ground welding equipment to any hydraulic or electrical components of the dock leveler. Always ground welding equipment to the dock leveler frame, NEVER to the platform.

Failure to follow these instructions may damage the motor, hydraulics, wiring, and/or control panel.

### **NOTICE**

DO NOT remove the shipping bands around the dock leveler lip until instructed to do so.

This page intentionally left blank.

# INSTALLATION

## Prepare Approach

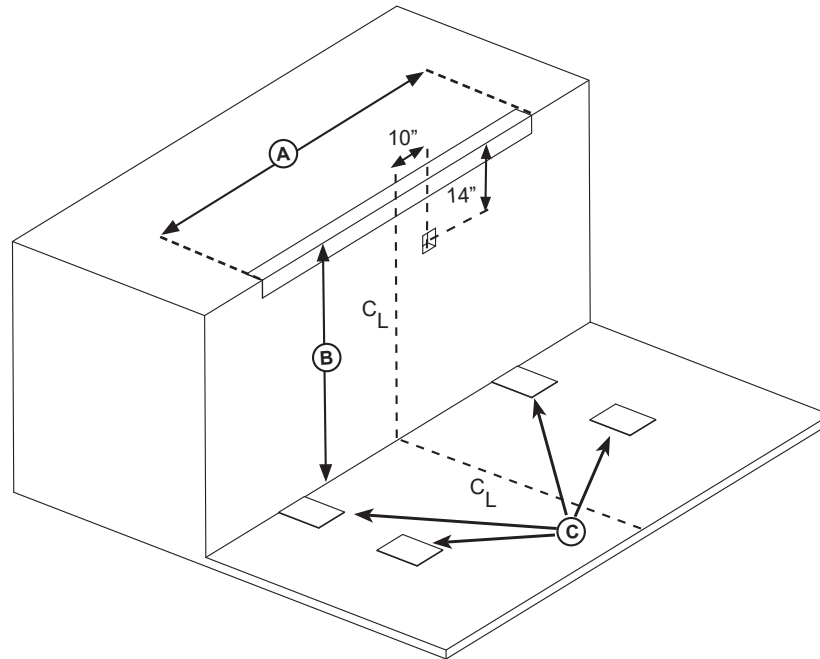

Figure 5

A—Imbed Width (Curb Steel)    B— Dock Floor-to-Pit Floor (Each Side)    C— Floor Imbeds

## Free-standing Frame Installation

Mini Ramp levelers are available with a free standing frame as shown in **Figure 6**. To install the free-standing frame model, follow the instructions below:

1. Remove all debris from the installation area and sweep the area clean.
1. Check the entire dock leveler opening for proper construction according to approved/certified pit drawings. Make sure that the walls of the opening are plumb and square. Check dock height, location of imbed plates, curb steel and J-box. See Figure 5 for example.
  - Measure pit width distance (**A**) at front of pit.
  - Measure dock floor-to-pit floor distance at each rear imbed (**B**).
  - Make sure the measurements correspond with the leveler to be installed.

If any measurement is off by more than 1/8 in. (3.18 mm), contact Systems, LLC Technical Services before proceeding.

2. Make sure the field junction box for the dock leveler is at the correct location per **Figure 5**.

## Prepare Dock Leveler

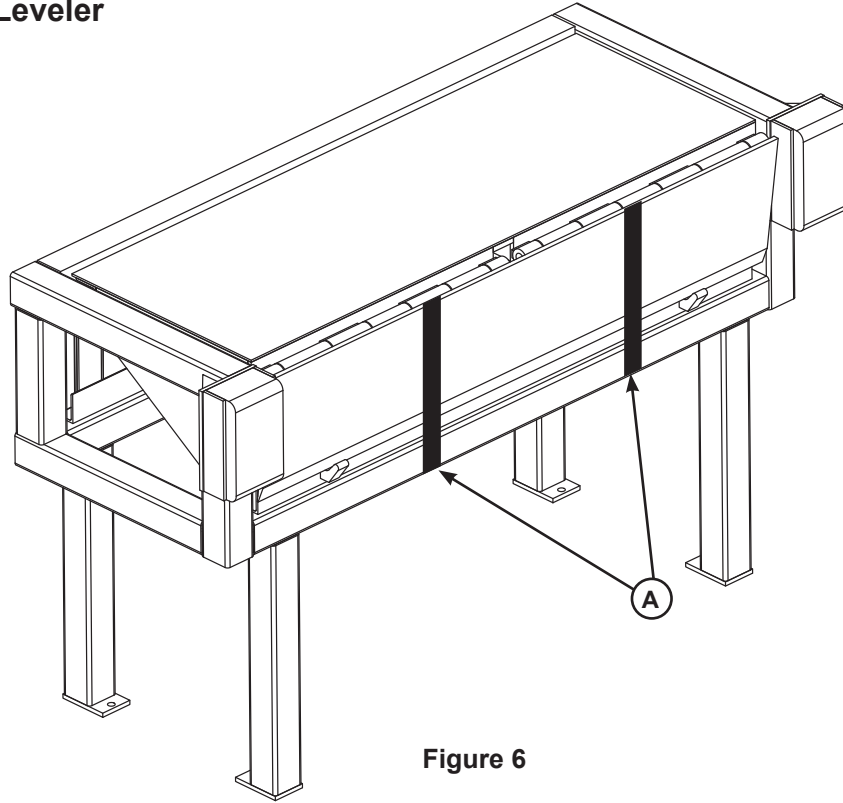

Figure 6

A— Shipping Bands (2 used)

Poweramp dock levelers are shipped with bands (A) around the platform lip and leveler frame (see Figure 6).

1. Some units are shipped with the control assembly, bumpers and outside light assembly attached to the unit. Remove these items from the leveler prior to installation. DO NOT remove the shipping bands.

**Note:** If the bumpers are welded to the stand, DO NOT remove. Remove any protective wood blocks that are attached to the leveler frame before putting the dock leveler into place.

### NOTICE

DO NOT remove the shipping bands (A) around the platform lip and leveler frame at this time. The shipping bands are needed to hold the leveler together during the installation process.

2. Proceed to “Install Dock Leveler” on Page 14.



# INSTALLATION

## Install Dock Leveler

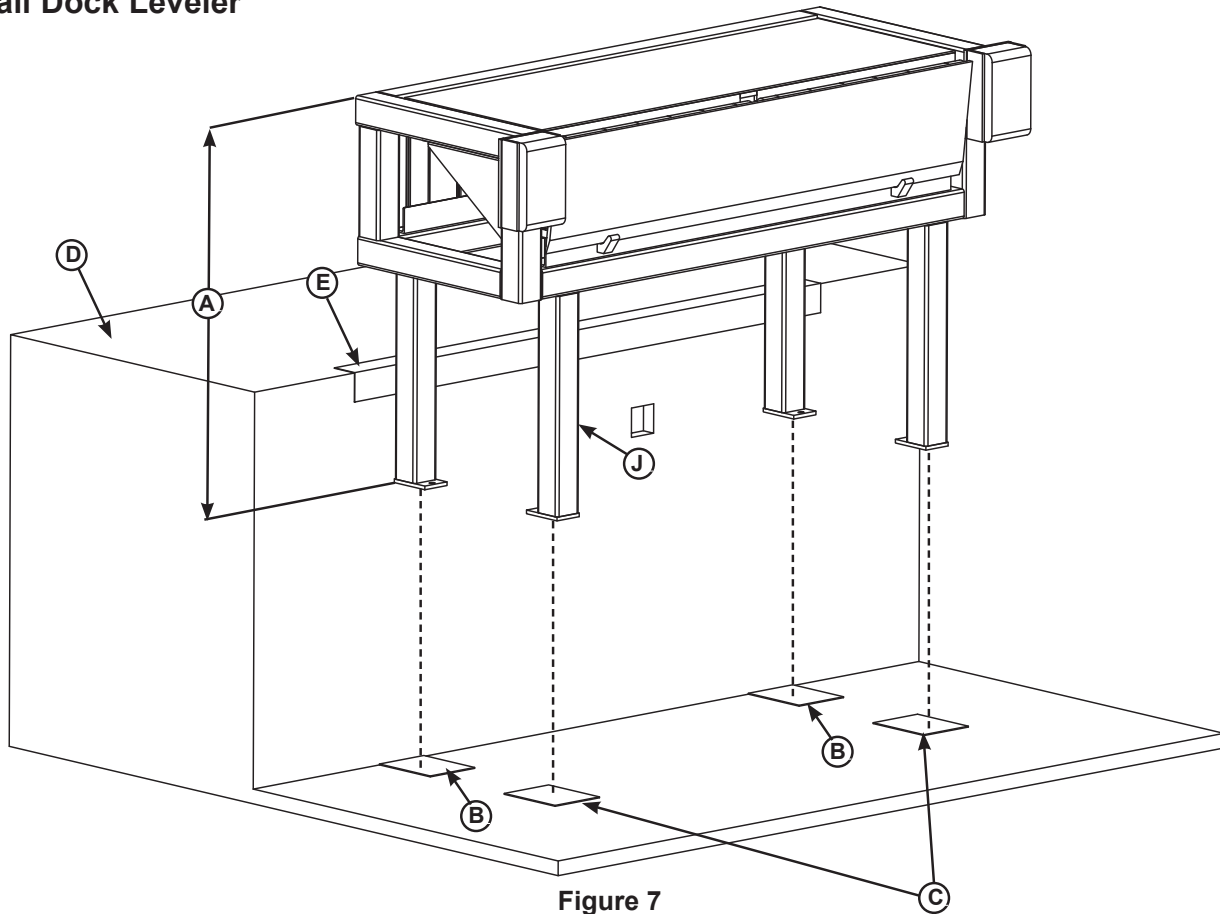

Figure 7

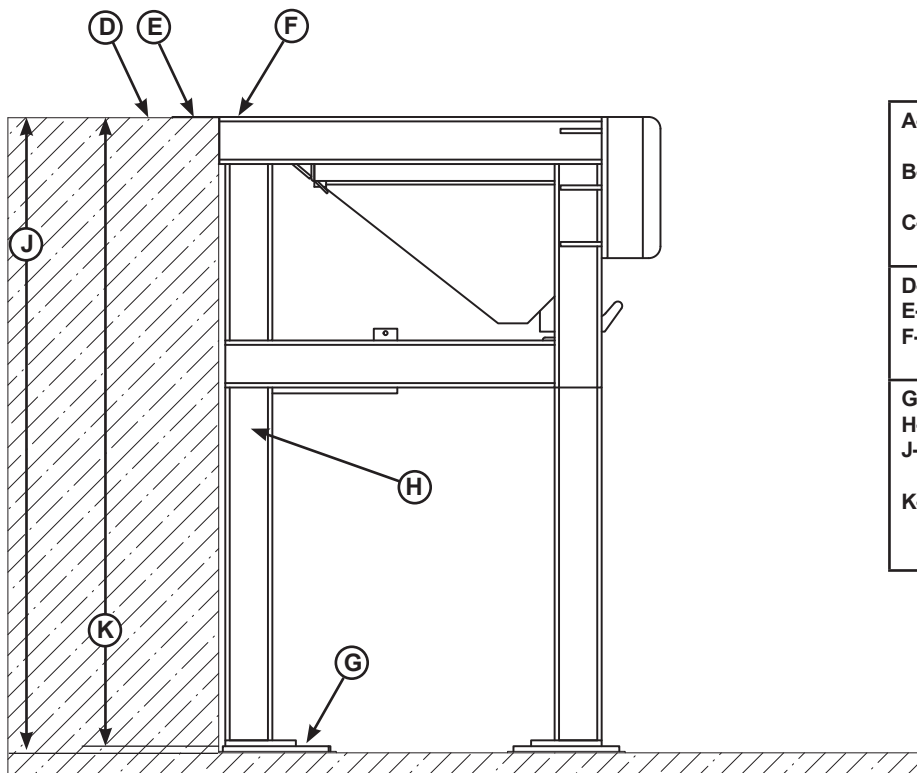

Figure 8

A— Distance (Leveler Frame Height)
B— Shim Locations (Under Rear Legs)
C— Shim Locations (Under Front Legs)
D— Dock Floor
E— Curb Angle
F— Rear Hinge Frame Angle
G— Shim Stack
H— Dock Leveler Frame
J—(Dock Floor-To Pit Floor)
K— Distance (Top of Shim Stack-to-Dock Floor)

## Install Dock Leveler (continued)

**Note:** Poweramp dock levelers are designed with a nominal 1/2" (12.7 mm) shimming distance to allow for pit inconsistencies.

1. Determine height of shim stack (**G**) for each shim location (**B**) by performing the following:

- a. Measure leveler frame height distance (**A**).
- b. Measure dock floor-to-pit floor distance (**J**) at each shim location (**B**). Write down the dimensions obtained at each location.
- c. Subtract distance (**A**) from distance (**J**) to obtain the shim height. Repeat for both shim locations.

2. Using the results obtained in step 1, create the individual shim stacks on the pit floor at locations (**B**). Build each shim stack (**G**) using the pyramid method (preferred) or stepped method, with the top shim having a minimum size of 5" x 7" (127mm x 177.8mm) and each successive lower shim being larger so the shims can be welded together using a fillet weld. DO NOT use offset method or straight method. See **Figure 9**.

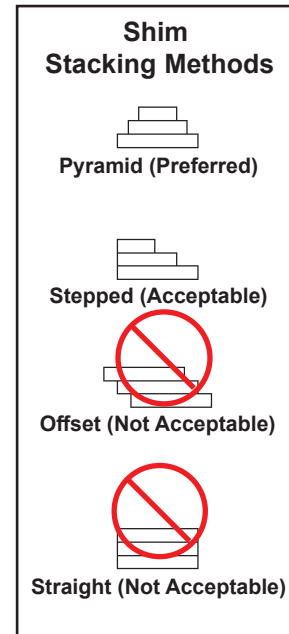

**Figure 9**

## NOTICE

The minimum size of the shim that contacts the leveler frame (i.e. the top shim of each shim stack) must be at least 5" x 7" (127mm x 177.8mm) to support the full width of the frame legs and to provide a shelf for a fillet weld.

Use the thickest shim stock possible for stability and weld penetration purposes. DO NOT use multiple layers of 1/8 in. (3.18 mm) or thinner shim stock.

3. Verify that each shim stack is at the correct height by measuring distance (**K**) [top of shim stack (**G**) to dock floor]. Distance (**K**) must equal the dock leveler height (**A**).

4. Place a 1/4 in. (6.6 mm) thick shim at locations (**C**).

**5. Note:** A 1/4" (6.6 mm) thick shim at locations (**C**) are used only as a starting point. The final shim stack height will be determined after dock leveler is positioned and leveled.

6. Using a forklift, position the forks under the leveler frame in the designated locations. Then position the dock leveler into place, so the rear hinge frame angle (**F**) is tight against rear curb angle (**E**) across full width of the leveler frame.

7. Allow legs of dock leveler to rest on the rear shims while keeping the front of the dock leveler level with the dock floor.

## WARNING

The dock leveler is heavy. Use a forklift with the appropriate lifting capacity and reach.

Always use a forklift or appropriate lifting device, whenever lowering or lifting a dock leveler into position.

8. Add shims at front shim locations (**C**) to create a level transition between dock floor (**D**) and platform (**E**) when leveler is resting on shims.

9. Ensure rear hinge frame angle (**F**) remains tight against rear curb angle (**E**) and that each leg is firmly contacting its respective shim stack.

# INSTALLATION

## Install Dock Leveler (continued)

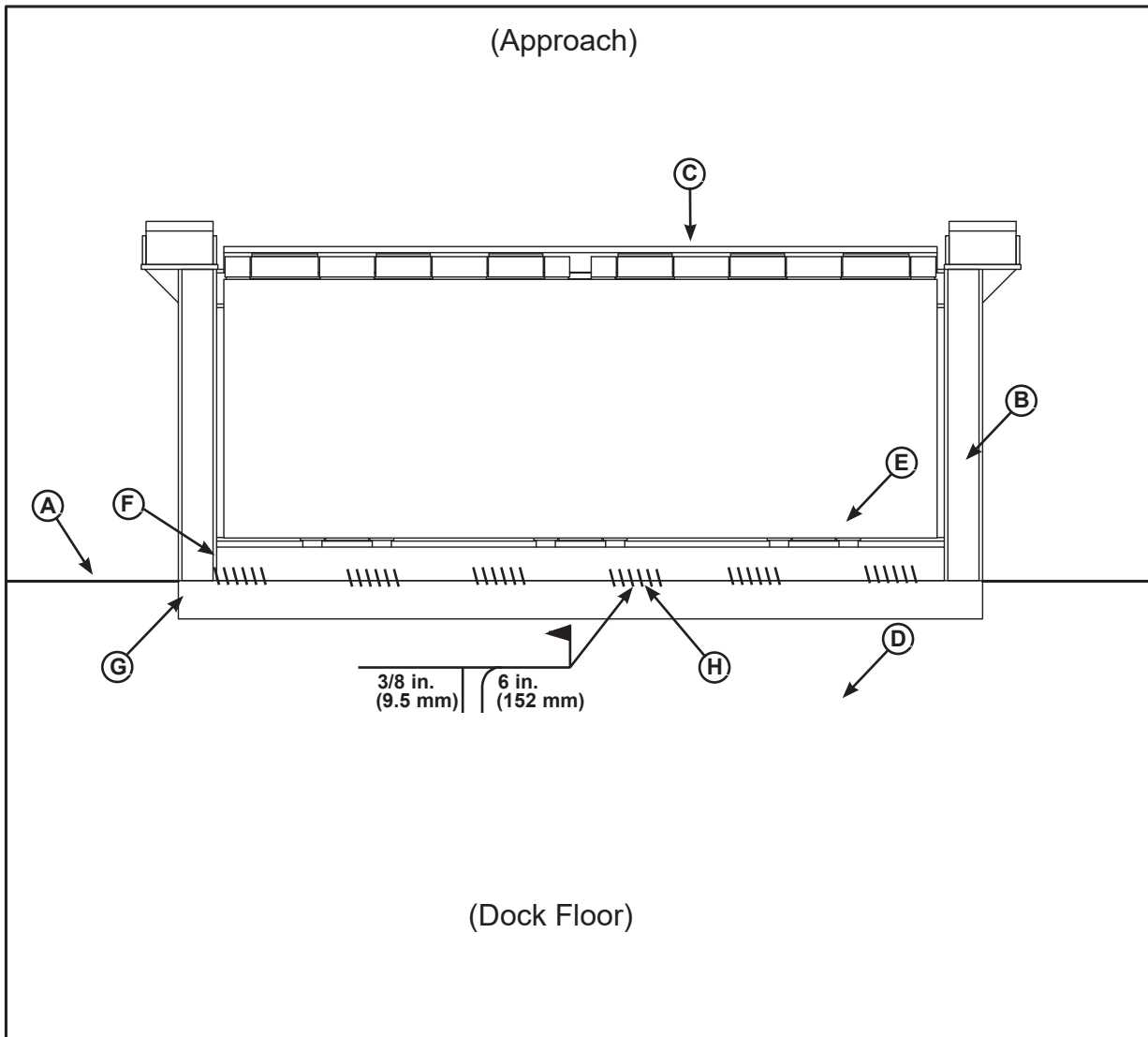

**Figure 11**

A— Front of Dock Pit  
B— Dock Leveler Frame

C— Lip Plate  
D— Dock Floor

E— Dock Leveler Platform  
F— Rear Hinge Frame  
Angle

G— Rear Pit Curb Angle  
H— Flare Bevel Weld, Typical  
(To Fit Spacing)

10. Add or remove shims as necessary until a smooth transition is obtained.

11. If leveler cannot be squared and/or made level as instructed in steps 8-10, contact Systems, LLC Technical Services.

12. With the rear hinge frame angle (F) tight against the rear pit curb angle (G), weld the rear hinge frame angle (F) to the rear pit curb angle (G) using a 3/8 in. (9.5 mm) flare bevel skip weld — each weld being 6 in. (152 mm) long.

- Start at each end with a 6 in. (152 mm) long weld. Space all the other welds out evenly, leaving approximately 6 in. (152 mm) space between each weld.

**Note:** Figure 11 shows a typical weld pattern. The weld pattern will vary slightly depending on size of dock leveler..

13. With leveler welded into place, remove the shipping bands from around lip and leveler frame.

## Install Dock Leveler (continued)

### **WARNING**

DO NOT grind or weld if hydraulic fluid or other flammable liquid is present on the surface to be ground or welded.

DO NOT grind or weld if uncontained hydraulic fluid or other flammable liquid is present. Stray sparks can ignite spills or leaks near the work area. Always clean up the oil leaks and spills before proceeding with grinding or welding.

Always keep a fire extinguisher of the proper type nearby when grinding or welding.

### **NOTICE**

DO NOT connect the dock leveler electrical wiring and ground connections until all welding has been completed.

DO NOT ground welding equipment to any hydraulic or electrical components of the dock leveler. Always ground welding equipment to the dock leveler frame, NEVER to the platform.

Failure to follow these instructions may damage the motor, hydraulics, wiring, and/or control panel.

### **NOTICE**

DO NOT weld continuously along the full length of the rear hinge frame angle. This can put unnecessary stress on the leveler components, causing the leveler to malfunction and shorten the lifespan of the affected components.

14. Complete the electrical connections between the leveler and the pit junction box, according to the provided electrical diagrams. Then raise the platform using the raise button on the control panel. (Refer to Control panel and Wiring on page 20)

### **WARNING**

If the platform is raised using an external lifting device or the hydraulic system is opened to atmosphere, air will enter into the hydraulic system.

Whenever this happens, always cycle the leveler at least 4 times using the leveler's own hydraulic power system before allowing the leveler to be put into service. This is to make sure all air is purged from the hydraulic cylinders.

15. Remove maintenance prop from the shipping location on dock leveler frame.\*

b. Position the maintenance prop in the service (upright) position. Ensure that the maintenance prop is properly inserted into both the platform and frame receivers as shown in **Figure 12**.

c. Lower the platform onto the prop using the external lifting device. Confirm the prop is properly engaged. DO NOT disconnect the external lifting device at this time.

# INSTALLATION

## Install Dock Leveler (continued)

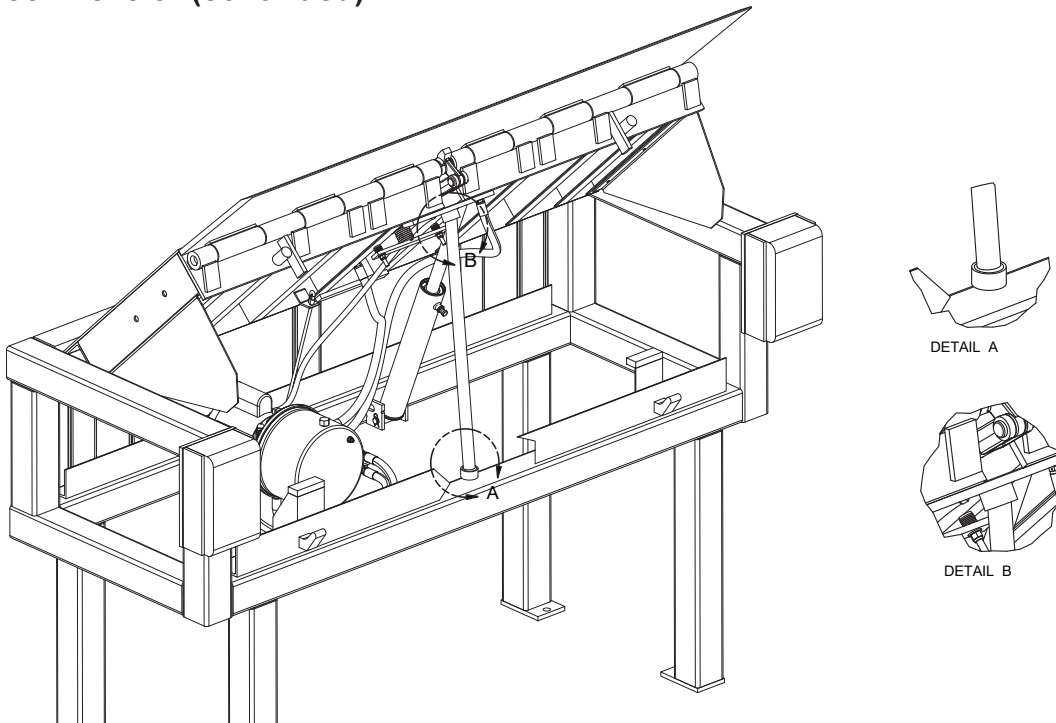

Figure 12

### **WARNING**

Make sure the platform is properly supported in the raised position (as shown in **Figure 12**) before attempting to finish weld the shims.

16. Finish weld all shims using a fillet weld.
  - Weld all shims within each shim stack to each other, then weld the shim stack to the leveler frame.
17. When all welding has been completed, paint all the welds and shims.
18. Proceed to “Install Control Panel and Wiring” on Page 20.

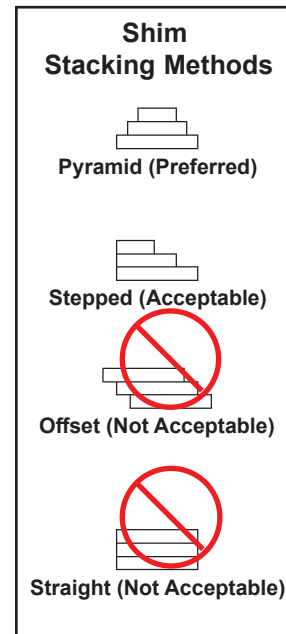

Figure 13

## Install Dock Leveler (continued)

This page intentionally left blank.

# INSTALLATION

## Install Control Panel and Wiring

### **! DANGER**

Make sure that the power source has been locked out and tagged according to OSHA regulations and approved local electrical codes.

### **! WARNING**

A hard hat or other applicable head protection should always be worn when working under or around a dock leveler.

Always stand clear of platform lip when working in front of the dock leveler.

### **! CAUTION**

All electrical work — including the installation of the disconnect panel, control panel, and final connections to the pit junction box — must be performed by a certified electrician and conform to all local and applicable national codes.

### **NOTICE**

DO NOT connect any dock equipment electrical wiring or ground connections until all welding has been completed.

DO NOT ground welding equipment to any electrical components of the dock equipment. Always ground welding equipment to the dock leveler frame, NEVER to the platform.

Failure to follow these instructions may damage the motor, wiring, and/or control panel.

### **NOTICE**

Where indicated, all components must be connected to a SAFETY EARTH GROUND that conforms to the 1999 National Electrical Code Section 250-50 section (a) or section (c) for a grounding electrode system.

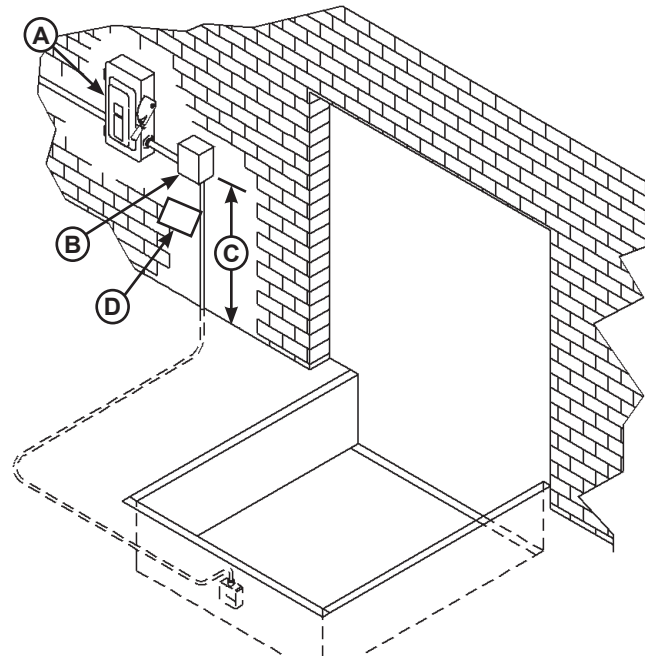

Figure 14

A— Disconnect Panel (provided by others)  
B— Control Panel  
C— Distance, 48 in. (1219 mm)  
D— Placard

1. Mount the control panel (B) so bottom of control panel-to-dock floor distance is 48 in. (1219 mm, C).
2. Install electrical disconnect panel (A) if not already installed (provided by others). It is recommended to locate disconnect panel adjacent to control panel (B).
3. Install and connect the control wiring as shown in installation drawings.
4. Connect the control wiring to the field wires in the dock equipment junction boxes. Refer to the electrical diagrams supplied with the dock equipment.

**Note:** When installing electrical controls in a temperature-controlled environment, the installer must determine an appropriate means to isolate/prevent thermal and vapor transfer through electrical conduit where conduit routing crosses temperature zones. Systems, LLC is not responsible for any damage due to moisture collecting inside the control panel caused by improper isolation/prevention of thermal and vapor transfer through the conduit. Refer to Tech Service Bulletin 19-053 for more information.

5. Install placard (D). Make sure placard is in plain view of dock leveler and/or vehicle restraint operations. Suggested placement of placard is near control box attached to electrical conduit by using nylon cable tie. See page 21.



## Placard Installation Instructions

- Owner/Users are responsible for the installation and placement of product placards.
- Make sure placard is in plain view of dock leveler and/or vehicle restraint operations.
- Suggested placement of placard is near control box attached to electrical conduit by using nylon cable tie. If there is no control box present, mount placard on wall to the immediate left of leveler at eye level.

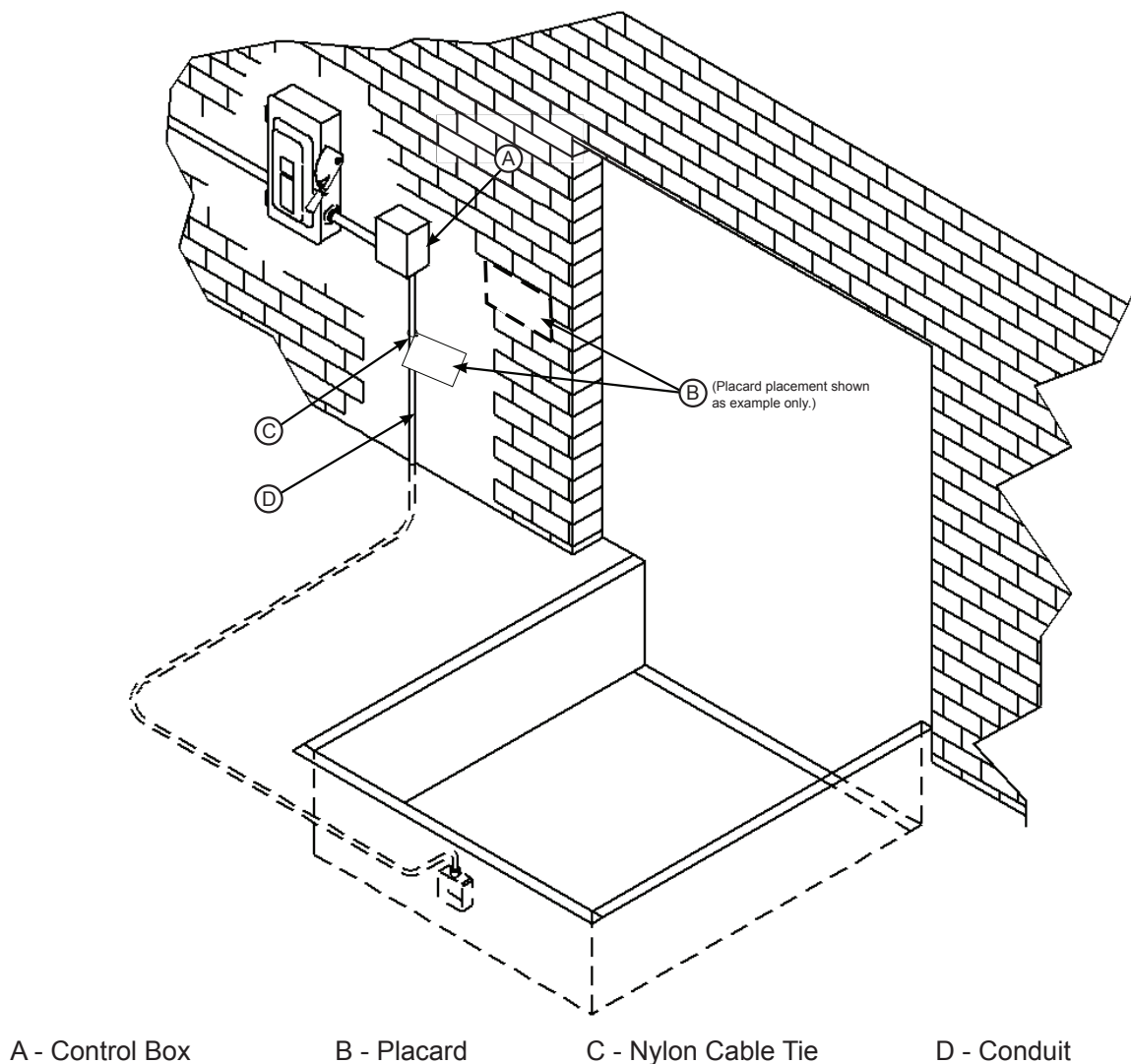

Figure 15

# INSTALLATION

## Put New Dock Leveler Into Service

### **WARNING**

A hard hat or other applicable head protection should always be worn when working under or around a dock leveler.

Always stand clear of platform lip when working in front of the dock leveler.

1. Disconnect the external lifting device if used.
2. Check that the leveler is flush with the dock floor and that the platform lip contacts both lip keepers evenly.

**Note:** If an excessive transition exists between the dock floor and leveler and/or lip does not contact both lip keepers evenly, contact Systems, LLC Technical Services for further instructions.

3. Turn the main electrical power ON.
4. Raise the leveler platform fully by pressing and holding the RAISE button.

**Note:** The platform of a properly operating dock leveler will automatically stop rising when it reaches its maximum full raised height, at which point, the lip extends. When the lip is fully extended, the powerpack will go into pressure relief. (If the lip does not extend correctly, see Troubleshooting section.)

5. Release the RAISE button to lower the platform. As long as there is no vehicle present at the dock, the platform will lower to the full below-dock position as the lip folds.

**Note:** If a transport vehicle is present, the platform will lower until the lip rests on the transport vehicle's bed. After the platform is resting on a trailer or in the below dock/ end load position, wait 30 seconds before attempting to store the leveler. Failure to wait 30 seconds will prevent the lip from folding completely

6. When the platform lowers to the full below-dock position, Press and hold the RAISE button until the platform rises just enough to clear the lip keepers, then release the RAISE button to allow the platform to lower to the cross-traffic (stored) position (lip engages lip keepers).

**Note:** For dock levelers equipped with the Auto Return To Dock (ARTD), the platform will automatically return to the cross-traffic position if the ARTD is enabled. When the platform is at the full below-dock position, there is a six-second delay before the platform will automatically rise to the cross-traffic position.

7. Perform steps 4-6 at least four times to purge any air that may be in the hydraulic system and to ensure proper operation.

8. Raise the platform to full height. Hold the platform at this position using the RAISE button and place the maintenance prop in the service (upright) position. Release the RAISE button to allow the platform to lower until it is resting on the maintenance prop.

### **DANGER**

Unless the dock leveler is equipped with a tethered remote, two people are required to engage the maintenance prop: one person to operate the unit, the other person to engage the maintenance prop.

In addition, it is recommended and good safety practice to use an additional means to support the dock platform and lip anytime when physically working in front of or under the dock leveler. This additional means may include, but is not limited to a boom truck, fork truck, stabilizing bar or equivalent.

9. Secure the maintenance prop in both the platform and frame receivers, to ensure proper engagement. See **Figure 16**

10. With the maintenance prop supporting the platform, remove the lifting brackets, if used.

11. Press and hold the RAISE button until the maintenance prop is removed from the upright position and properly secured in the stored position. Release the RAISE button and allow the platform to lower. If the lip has extended and the leveler lowered below dock, wait 30 seconds and then store the leveler.

## Operational Precautions

### **DANGER**

Stay clear of dock leveler and vehicle restraint when transport vehicle is entering or leaving dock area.

DO NOT move or use the dock leveler or restraint if anyone is under or in front of leveler.

Keep hands and feet clear of pinch points. Avoid putting any part of your body near moving parts.

### **WARNING**

Only trained personnel should operate the dock leveler.

DO NOT use a broken or damaged dock leveler. Make sure proper service and maintenance procedures have been performed on leveler before using.

Transport vehicle wheels must be chocked unless a vehicle restraint is used. Never remove the wheel chocks until loading/unloading is finished and transport driver has been given permission to leave.

Make sure platform lip rests on the transport vehicles bed with at least 4 in. (102 mm) of overlap.

Maintain a safe distance from side edges of leveler during the loading/unloading process.

### **WARNING**

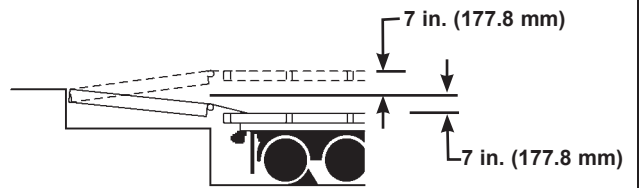

The Mini Ramp hydraulic dock leveler is designed to compensate for a maximum  $\pm 7$  in.\* (177.8 mm) of height difference between the loading dock and the transport vehicles bed. DO NOT use the dock leveler if the transport vehicles bed is more than 7 in. (177.8 mm) higher or lower than the dock floor.

\*Service height may vary with design specifications

DO NOT overload the dock leveler.

DO NOT operate any equipment while under the influence of alcohol or drugs.

DO NOT leave equipment or material unattended on the dock leveler.

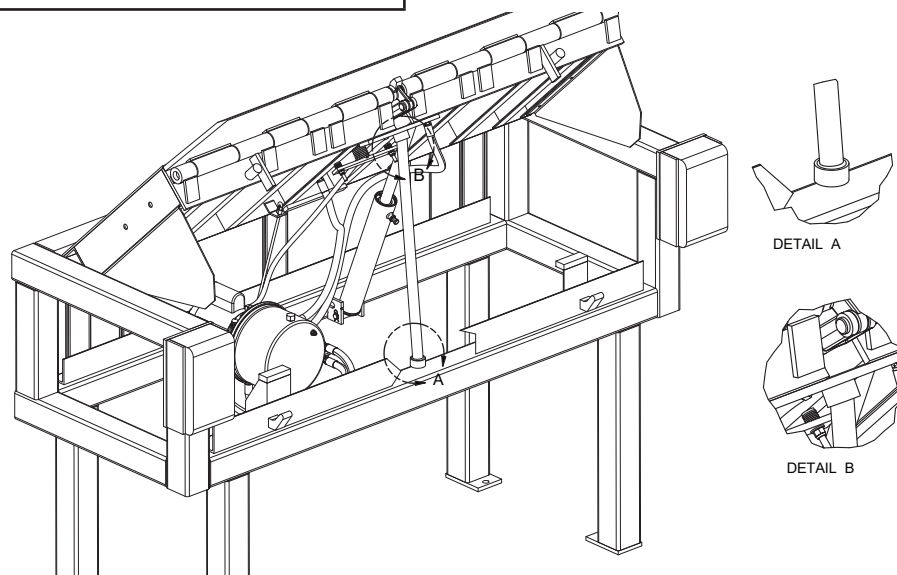

Figure 16

# OPERATION

## Operating Instructions

### Ramp Loading/Unloading

1. Check to make sure the transport vehicle is positioned squarely against dock bumpers.
2. Instruct driver to remain at the dock until the loading or unloading process has been completed.
3. Chock the transport vehicle wheels, or use a vehicle restraint if available.
4. Extend the dock leveler onto the transport vehicle as follows:
  - a. Raise the platform by pressing and holding the RAISE button.
  - b. Hold the RAISE button until the lip is fully extended, then release the RAISE button. The platform will lower until the lip is resting on the transport vehicle bed.
  - c. Make sure that the lip is fully extended and supported on the transport vehicle along the entire width of the platform, with at least 4 in. (102 mm) of lip contacting the transport vehicle bed. See Figure 17.

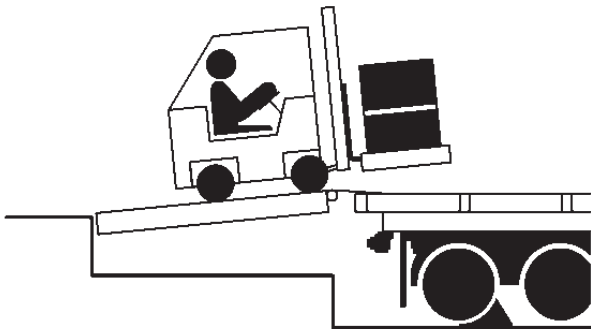

**Figure 17**

5. Proceed with loading or unloading the transport vehicle.

Note: After the platform is resting on a trailer or in the below dock/ end load position, wait 30 seconds before attempting to store the leveler. Failure to wait 30 seconds will prevent the lip from folding completely.

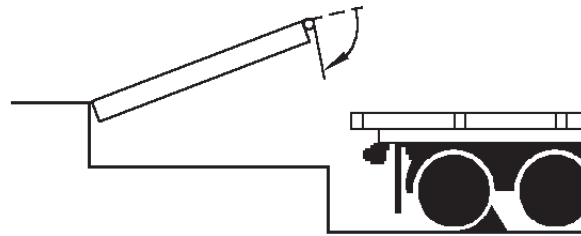

**Figure 18**

6. When loading or unloading is finished, raise the platform by pressing and holding the RAISE button until the lip folds enough to land in the lip keepers, then release the RAISE button. The platform will return to the cross-traffic position. See Figure 18.
7. Remove chocks from transport vehicle wheels, or release the vehicle restraint if used.
8. Indicate to driver that the transport vehicle may leave the dock.

## Operating Instructions (continued)

### End Loading/Unloading

1. Check to make sure the transport vehicle is positioned squarely against dock bumpers.
2. Instruct driver to remain at the dock until the loading or unloading process has been completed.
3. Chock the transport vehicle wheels, or use a vehicle restraint if available.

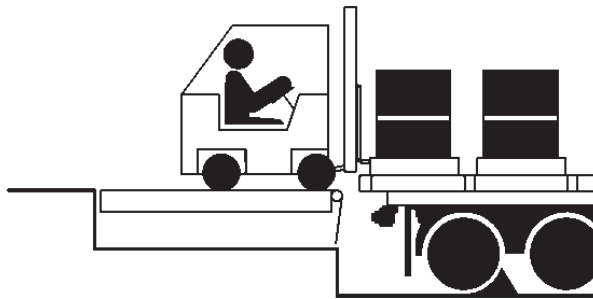

**Figure 19**

4. If transport vehicle bed is at or above dock floor level, leave leveler at the cross-traffic position and proceed with loading or unloading (see Figure 19). If transport vehicle bed is below the dock floor level, continue with Step 5.
5. Raise the platform by pressing and holding the RAISE button until the lip extends just enough to clear the lip keepers, then release the RAISE button.
6. Allow the platform to drift down to the full below-dock position.



**Figure 20**

7. Proceed with loading or unloading (see Figure 20).

**Note:** When end unloading is finished and access to the rest of the transport vehicle is still required,

the platform lip will need to be extended. See Ramp Loading/Unloading Instructions on page 26 for further instructions.

8. When end loading or unloading is finished, raise the platform by pressing and holding the RAISE button until the lip folds enough to land in the lip keepers, then release the RAISE button. The platform will return to the cross-traffic position.
9. Remove chocks from transport vehicle wheels, or release the vehicle restraint if used.
10. Indicate to driver that the transport vehicle may leave the dock.

# OPERATION

## Optional Equipment

### Quick Cycle Lip Extend (Lip Out)

**Note:** For dock levelers equipped with optional Quick Cycle Lip Extend/Lip Out, the dock leveler lip can be extended independently of the leveler platform with the following sequence:

1. Complete steps 1-4 in “Operating Instructions” on page 24.
2. When leveler begins to raise, press and hold the LIP button in addition to the RAISE button.
3. When lip has fully extended, release RAISE and LIP button. Leveler will descend into transport vehicle with lip fully extended.
4. Continue with step 5 in “Operating Instructions.”

### Emergency Stop (E-Stop)

**Note:** For dock levelers equipped with optional Emergency Stop (E-Stop), dock leveler can be halted in place by using the Emergency Stop button:

1. While operating any function of the dock leveler, press the Emergency Stop button (**E**).
2. Equipment being operated will halt in place.
3. When hazard has been cleared or system must be operated, pull the Emergency Stop button outward.
4. Continue operating dock equipment as needed.

### Auto Return To Dock (ARTD)

**Note:** For dock levelers equipped with optional Auto Return To Dock (ARTD), the dock leveler can self-store if a transport vehicle departs the loading dock before the platform is stored.

To enable Auto Return To Dock, turn the ARTD switch to the ON position. If end loading or unloading is required, turn the ARTD switch to the OFF position and follow the steps on page 25. When end loading or unloading is complete, turn the ARTD switch back to the ON position, and the dock leveler will self-store.

## **CAUTION**

Whenever end loading or unloading with the platform in the below-dock position, make sure the ARTD switch is in the OFF position. **DO NOT** turn the ARTD switch to the ON position until end loading or unloading is finished.

## **WARNING**

When Emergency Stop is active, **DO NOT** go under the dock leveler, walk or drive on the dock leveler, or leave forklift and/or material sitting on the leveler!

If Emergency Stop button is pressed with the dock leveler unsupported in the working zone, the leveler will descend when E-Stop is released!

Always make sure the platform is properly supported in the raised position before entering the pit or going under the dock leveler.

## Maintenance Precautions

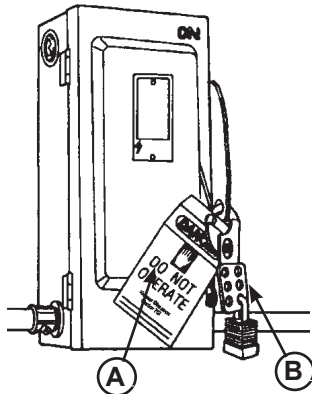

Figure 21

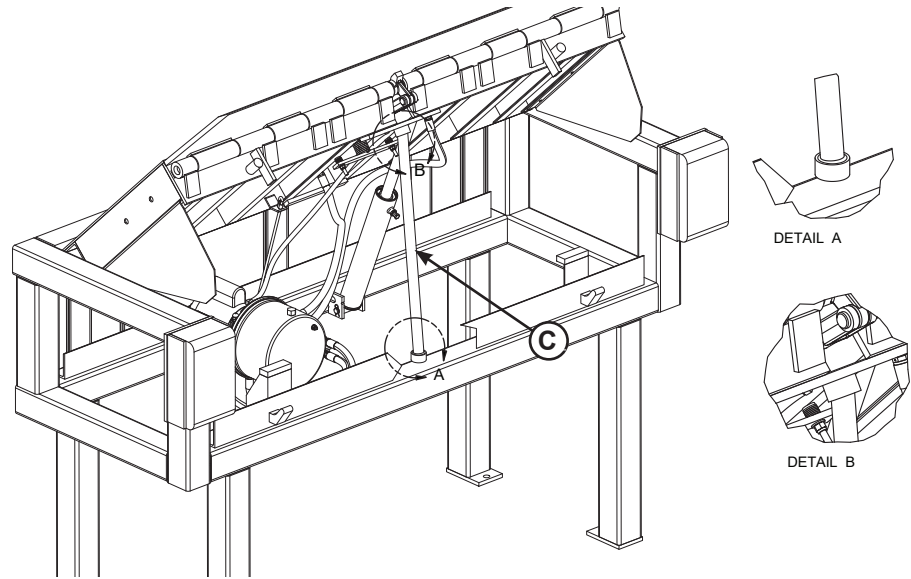

Figure 22

A— Tag Out Device

B—Lock Out Device

C — Maintenance Prop

### DANGER

Unless the dock leveler is equipped with a tethered remote, two people are required to engage the maintenance prop: one person to operate the unit, the other person to engage the maintenance prop.

In addition, it is recommended and good safety practice to use an additional means to support the dock platform and lip anytime when physically working in front of or under the dock leveler. This additional means may include, but is not limited to a boom truck, fork truck, stabilizing bar or equivalent.

When working with electrical or electronic controls, make sure that the power source has been tagged (A) and locked out (B) according to OSHA regulations and approved local electrical codes (see **Figure 21**).

Whenever maintenance is to be performed under the dock leveler platform, support the platform with maintenance prop (C). Position the maintenance prop in the platform and frame receivers, while staying clear of the lip. See **Figure 22**. The lip will fold down after the platform has rested on the maintenance prop.

Only the person servicing the equipment should have the capability to remove the lockout devices. The tag out devices\* must inform that repairs are in process and clearly state who is responsible for the lockout condition.

### WARNING



Always post safety warnings and barricade the work area at dock level and ground level to prevent unauthorized use of the unit before maintenance is complete.

### WARNING

A hard hat or other applicable head protection should always be worn when working under or around a dock leveler.

Always stand clear of platform lip when working in front of the dock leveler.

\* Refer to OSHA regulations 1910.146. Confined Space and 1910.147. Lockout/Tagout



# MAINTENANCE

## Periodic Maintenance

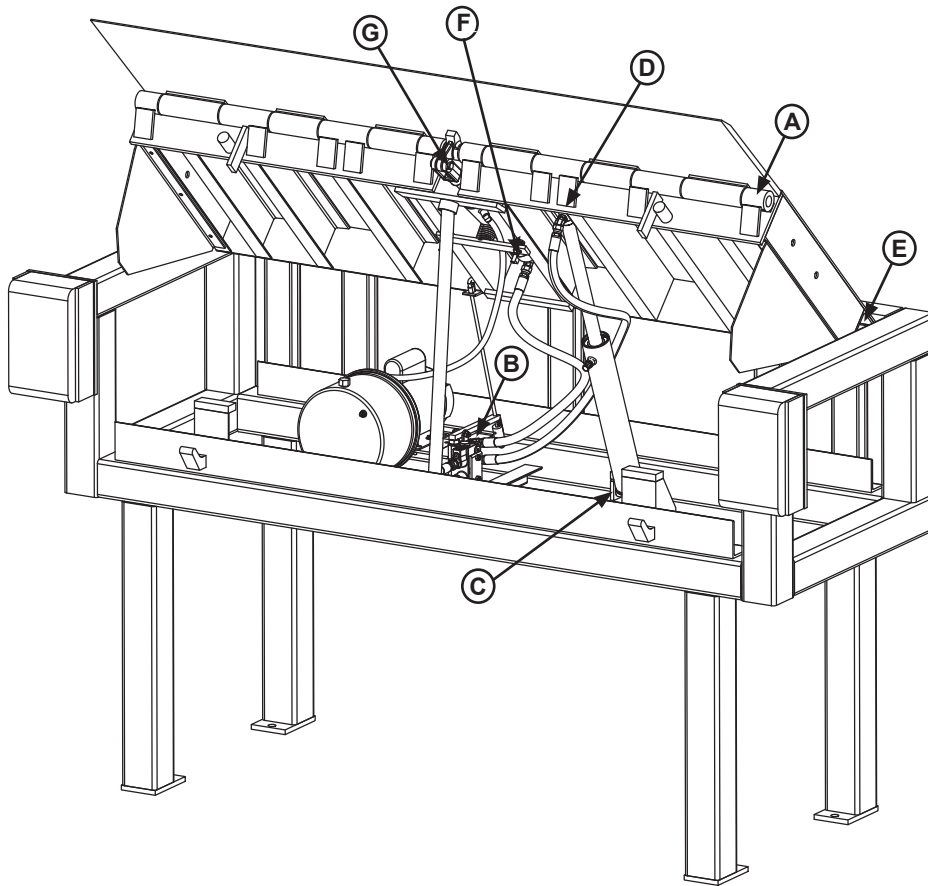

**Figure 23**

A— Lip Hinge Area

B— Logic Block Valve Lever Pivot

C— Frame Cylinder Trunnion

D— Platform Cylinder to Platform Pin

E— Platform Hinge Area

F— Lip Cylinder-to-Platform Pin

G— Lip lifter and lift cylinder pin.

To ensure normal operation of the dock leveler, use only aircraft hydraulic fluid designed to meet or exceed military specification MIL-H-5606-G. It is recommended that the following hydraulic fluids be used:

- ULTRA-VIS-HVI-15
- Aero Shell Fluid 4 or Fluid 41
- Mobil Aero HFA Mil-H5606A or Aero HF
- Texaco Aircraft Hydraulic Oil 15 or 5606
- Exxon Univis J13
- Castrol Brayco Micronic 756

These fluid brands can be mixed together. Use of hydraulic fluids with equivalent specifications to those listed here are acceptable.

## **NOTICE**

Use of fluids that do not have equivalent specifications to those in the preceding list will result in abnormal operation of the dock leveler and voiding of warranty.

## Weekly Maintenance

- Operate the dock leveler through the complete operating cycle to maintain lubrication.

**Note:** To thoroughly inspect the platform hinge area, put the platform in the full below-dock position.

- Inspect the platform hinge and the lip hinge areas. The hinge areas must be kept free of dirt and debris. Build-up of foreign material in the hinge areas will cause abnormal operation.
- Inspect warning decals and placards. Replace if damaged or missing.

## Quarterly Maintenance

- Complete Weekly Maintenance.
- Inspect the following for damage/abnormal wear:
  - Check welds for cracks.
  - Cylinder pins and mounting holes.
  - Lip hinge pins and rear hinge pins.
  - Check toe guards for free movement.
  - Check J-box for water damage.
  - Inspect hoses, cylinders, fittings and powerpack.
  - Control box and conduit for damage.
  - Bumpers for more than 1" of wear. Replace worn, loose, damaged or missing bumpers.
  - Side and rear weather seals.
- Lubricate the following areas with light weight machine oil (see Figure 23):
  - (A)— Lip hinge area unless equipped with grease fittings (apply oil to the top of the entire length of lip hinge when platform is at the full below-dock position and lip is folded).
  - (E)— Platform hinge area (apply oil to top of all platform hinges when platform is at the full below-dock position).
  - (D)— Hoist Cylinder-to-platform frame pin.
  - (F)— Lip cylinder-to-platform frame pin.
  - (G)— Lip lifter and lift cylinder pin.
- Lubricate the following areas with white lithium grease (see Figure 23):
  - (B)— Valve lever pivot and top of logic block spool valve.
  - (C)— All Hoist Cylinder trunnions.

**Note:** Apply grease to lip hinge grease fittings if equipped.

## **NOTICE**

Failure to properly lubricate the dock leveler will cause abnormal operation of the leveler.

- Check reservoir fluid level (P, see Figure 24):
  1. Raise the platform to full height. Hold the platform at this position using the RAISE button and place the maintenance prop in the platform and frame receivers. Release the RAISE button to allow the platform to lower until it is resting on the maintenance prop .

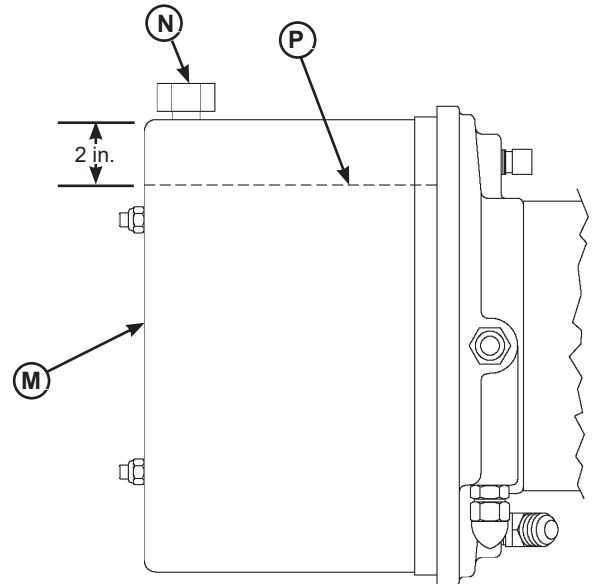

**Figure 24**

M — Reservoir  
N — Breather Cap

P — Fluid Level

2. Turn OFF all electrical power to the leveler.
3. Remove breather cap (N).
4. Measure fluid level. The fluid level should be approximately 2 in. (51 mm) from top of reservoir (M) with platform at the below-dock position.
5. Add hydraulic fluid if necessary. Use only recommended fluid (see page 28).
6. Install breather cap.
7. Turn ON electrical power to the leveler.
8. Return the platform to the cross-traffic position.

## Yearly Maintenance

- Complete Quarterly Maintenance.
- Change hydraulic oil (may be required more often depending upon conditions).

# ADJUSTMENTS

## Adjust Main Pressure Relief

### **DANGER**

Unless the dock leveler is equipped with a tethered remote, two people are required to engage the maintenance prop: one person to operate the unit, the other person to engage the maintenance prop.

In addition, it is recommended and good safety practice to use an additional means to support the dock platform and lip anytime when physically working in front of or under the dock leveler. This additional means may include, but is not limited to a boom truck, fork truck, stabilizing bar or equivalent.

### **WARNING**

When service under the dock leveler is required, always lock all electrical disconnects in the OFF position after raising the platform and engaging the maintenance prop.

Always post safety warnings and barricade the work area at dock level and ground level to prevent unauthorized use of the dock leveler before maintenance is complete.

A hard hat or other applicable head protection should always be worn when working under or around a dock leveler.

Always stand clear of platform lip when working in front of the dock leveler.

### Main Pressure Relief Adjustment

**Note:** The main pressure relief may need to be *increased* if the platform does not rise or rises slowly and the system operates in pressure relief mode.

The main pressure relief may need to be *decreased* if the pump motor loads down when platform reaches the fully raised position.

See Troubleshooting section on pages 36-39 for more information.

1. Raise the platform to full height and engage the maintenance prop in the service position.
2. Turn OFF all electrical power to the dock leveler.

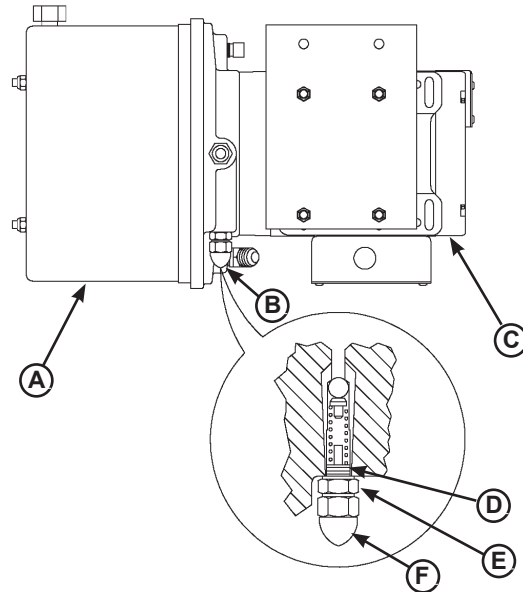

**Figure 25**

- |                         |                       |
|-------------------------|-----------------------|
| A— Reservoir            | D—Hex Adjusting Screw |
| B— Main Pressure Relief | E— Jam Nut            |
| C— Pump/Motor           | F— Acorn Nut          |

3. Attach lock out/tag out devices.
4. Remove acorn nut (F). See **Figure 25**.
5. Loosen jam nut (E).
6. Adjust hex adjusting screw (D) as follows:
  - To increase pressure relief, turn hex screw clockwise one full turn.
  - To decrease pressure relief, turn hex screw counterclockwise one full turn.
7. Tighten the jam nut and reinstall the acorn nut.
8. Turn ON electrical power to the dock leveler.
9. Remove lock out/tag out devices.
10. Disengage the maintenance prop.
11. Cycle leveler and verify pressure relief setting.
12. Repeat steps 1– 9 as necessary.

**Note:** If dock leveler is combined with PowerHook vehicle restraint, see PowerHook manual for procedure.

## Adjust Cable Weight and Down Speed Control

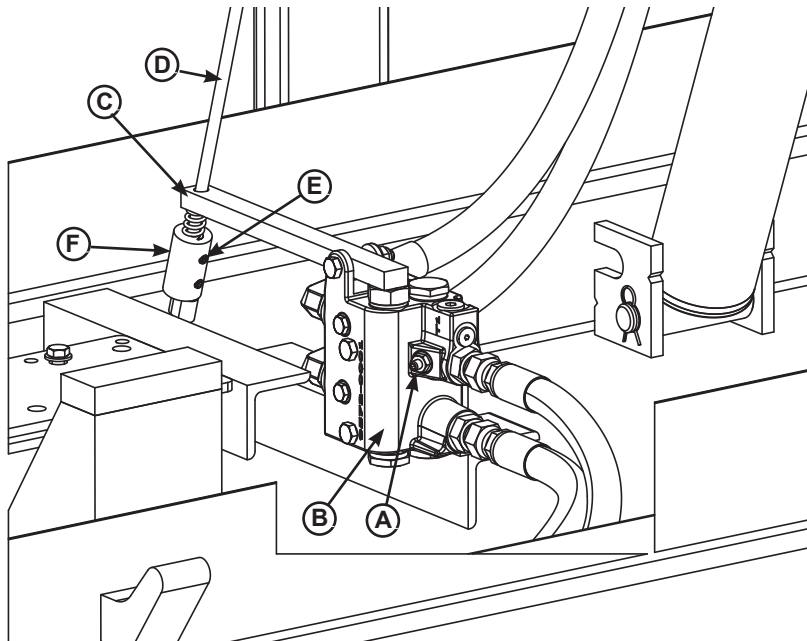

Figure 26

A— Down Speed Control  
Adjusting Screw  
B— Logic Block

C— Valve Lever  
D— Cable

E— Set Screw (2 used)  
F— Cable Weight

### Cable Weight Adjustment

If the platform lip does not extend, or extends too soon, cable weight (**F**) may need adjustment. The cable weight is attached to cable (**D**) and is located underneath the platform, directly behind the logic block (**B**).

The factory setting causes the lip to fully extend when 1 – 3 in. (25.4 – 76.2 mm) of travel is left in the platform cylinder.

**Note:** To prevent the cable weight from accidentally falling off the cable when adjusting the weight, attach a locking pliers or similar device to the cable just below the cable weight. If adjustment requires that the weight be moved down, allow sufficient distance between pliers and weight before adjusting.

To adjust the cable weight (see Figure 26):

- Loosen (do not remove) set screws (**E**).
- To make lip extend sooner, slide the weight up.
- To make lip extend later, slide the weight down.
- Tighten set screws.

### Down Speed Control Adjustment

If the dock leveler does not lower at a normal rate, the down speed control may require adjustment. The adjusting screw (**A**) is a hex screw located in logic block (**B**), directly behind the upper front hose connection.

Use 1/4 turn increments when adjusting the down speed control. Check platform lowering speed after each adjustment.

To adjust the speed control (see Figure 26):

- Loosen the jam nut.
- To decrease the lowering speed, turn adjusting screw (**A**) clockwise.
- To increase the lowering speed, turn adjusting screw (**A**) counterclockwise.
- Tighten the jam nut.

# ADJUSTMENTS

## Adjust Auto Return To Dock (ARTD)

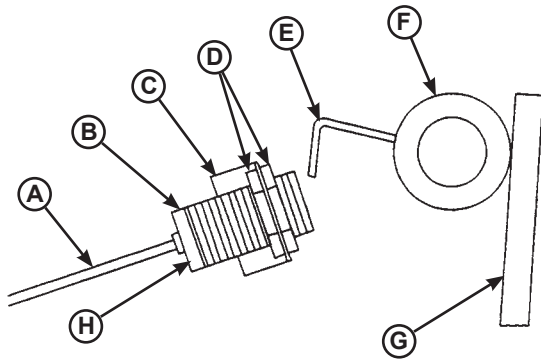

Figure 27

- |                     |                    |
|---------------------|--------------------|
| A— Cable            | E— Target          |
| B— Proximity Switch | F— Lip Hinge Tube  |
| C— Bracket          | G— Platform Lip    |
| D— Lock Nuts        | H— Indicator Light |

### Auto Return To Dock (ARTD)

PR levelers can be equipped with optional Auto Return To Dock (ARTD) if leveler is not interlocked with a transport vehicle restraint.

The ARTD uses a proximity switch (B) located under the platform and a piece of angled steel called the target (E) that is attached to the lip hinge tube (F). See **Figure 27**.

The proximity switch provides a six-second delay after the platform has lowered to the full below-dock position, after which the platform will return to the cross-traffic position. The switch also contains an indicator light (H) that can be used for diagnosing and adjusting the switch.

**Note:** Some proximity switches have an indicator light at the back of the housing and some have the light at the side of the housing.

### **! WARNING**

When service under the dock leveler is required, always lock all electrical disconnects in the OFF position after raising the platform and engaging the maintenance prop.

### **! WARNING**

Always post safety warnings and barricade the work area at dock level and ground level to prevent unauthorized use of the dock leveler before maintenance is complete.

### **! WARNING**

Always stand clear of platform lip when working in front of the dock leveler.

The maintenance prop **MUST** be in the service (upright) position when working under the dock leveler.

Unless the dock leveler is equipped with a tethered remote, two people are required to engage the maintenance prop: one person to operate the unit, the other person to engage the maintenance prop.

## Adjust Auto Return To Dock (ARTD, continued)

### NOTICE

Whenever proximity switch and target are adjusted, check for interference between target and switch before operating the leveler. Damage to switch will occur if the target contacts the switch.

The maximum torque for proximity switch lock nuts is 27 N·m (29 lb-ft). Damage to switch will occur if maximum torque is exceeded.

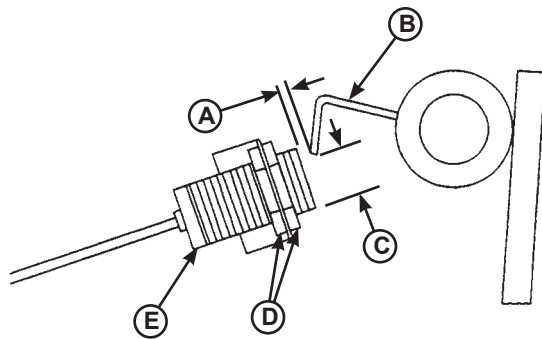

Figure 28

A— 1/4 in. (6.4 mm)  
Approximate  
B— Target

C— 1 in. (25.4 mm)  
Approximate  
D— Lock Nuts  
E— Proximity Switch

**Note:** Distances (A and C) in Figure 28 are typical factory settings. Use these dimensions only as a starting point when adjusting the proximity switch and target, especially if switch and/or target have been replaced.

When dimensions (A and C) are obtained, the proximity switch and target may need finer adjustments to get the ARTD to operate as desired.

### Adjust Auto Return To Dock (ARTD)

1. Raise platform fully and engage the maintenance prop in the service position. Allow platform to rest on the prop so the lip will fully fold until it contacts the lip stops.
2. Turn OFF all electrical power to the leveler and lock out/tag out the electrical power supply.
3. Loosen lock nuts (D). Adjust proximity switch (E) to obtain distance (A). Tighten lock nuts.
4. Bend target (B) as needed to obtain distance (C). Recheck distance (A) and readjust if necessary.

**Note:** At least two people may be required to manually move the lip.

5. After adjusting proximity switch and target, slowly move the lip up by hand while observing the target and proximity switch. The target **MUST NOT** contact the switch, otherwise, damage to switch will occur. Readjust switch and/or target if necessary, then recheck for interference.

6. Remove lock out/tag out and turn ON electrical power to the leveler.

7. Disengage the maintenance prop.

8. Turn the ARTD switch (on control panel) to the ON position.

9. Raise the platform until the lip is fully extended, then allow the platform to drift to the below-dock position. After approximately 6 seconds, the platform should return to the cross-traffic position.

10. Adjust the proximity switch and target as necessary. Make small adjustments, then operate the dock leveler to check results. Do this until satisfied with the ARTD operation.

**Note:** Use the illustrations on pages 32-34 to assist in fine tuning and/or diagnosing the ARTD operation.

# ADJUSTMENTS

## Adjust Auto Return To Dock (ARTD, continued)

### Full Below-Dock Position

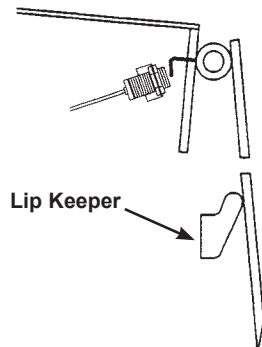
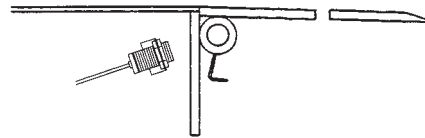

**Figure 29**

Whenever the platform lip is at the full below-dock position, the following conditions will exist for a normally operating ARTD (see **Figure 29**):

- Target in sensing area of proximity switch.
- Proximity switch ON (closed, signal sent to the control panel).
- Proximity switch indicator light is ON.
- Platform will automatically rise after approximately a six-second delay, then return to the cross-traffic position.

### Lip Fully Extended Position

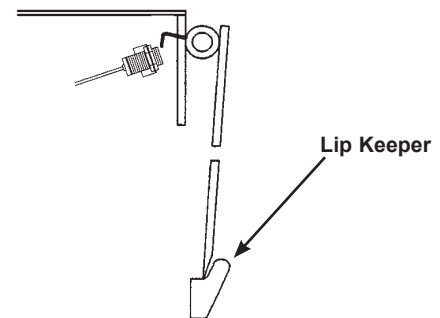

**Figure 30**

Whenever the platform lip is at the fully extended position, the following conditions will exist for a normally operating ARTD (see **Figure 30**):

- Target not in the sensing area of proximity switch.
- Proximity switch OFF (open, no signal sent to the control panel).
- Proximity switch indicator light is OFF.
- If the platform lip is resting on the transport vehicle bed, the platform will stay at this position unless the operator activates the leveler.

### Cross-Traffic/Lip Fully Folded Position



**Figure 31**

**Note:** The platform lip is fully folded when the platform is at the cross-traffic position (stored, with lip engaged with keepers) or when platform is resting on the maintenance prop.

Whenever the platform lip is at the cross-traffic or fully folded position, the following conditions will exist for a normally operating ARTD (see **Figure 31**):

- Target not in the sensing area of proximity switch.
- Proximity switch OFF (open, no signal sent to control panel).
- Proximity switch indicator light is OFF.
- Platform stays at this position unless the operator activates the leveler.



This page intentionally left blank.

# TROUBLESHOOTING

## DANGER

Unless the dock leveler is equipped with a tethered remote, two people are required to engage the maintenance prop: one person to operate the unit, the other person to engage the maintenance prop.

In addition, it is recommended and good safety practice to use an additional means to support the dock platform and lip anytime when physically working in front of or under the dock leveler. This additional means may include, but is not limited to a boom truck, fork truck, stabilizing bar or equivalent.

## WARNING

When service under the dock leveler is required, always lock all electrical disconnects in the OFF position after raising the platform and engaging the maintenance prop.

Always post safety warnings and barricade the work area at dock level and ground level to prevent unauthorized use of the dock leveler before maintenance is complete.

A hard hat or other applicable head protection should always be worn when working under or around a dock leveler.

Always stand clear of platform lip when working in front of the dock leveler.

**Before performing the detailed troubleshooting procedures, check the following items first:**

- Check all fuses inside the control panel(s). Replace any blown fuse(s) with a fuse of equal specification.
- Make sure the correct voltages are present at the proper locations inside the control panel(s).

Symptom	Possible Cause	Solution
Platform does not rise. Motor does not energize.	Motor overload device tripped.	Reset overload relay or breaker. Determine cause of device tripping.
	Motor starter (three-phase) or motor relay (single-phase) not energizing.	<p>Check voltage at starter or relay coil.</p> <ul style="list-style-type: none"> <li>• If voltage is present and starter or relay does not energize, replace starter or relay.</li> <li>• If voltage is not present, check all components in series with the starter or relay coil.</li> </ul>

# TROUBLESHOOTING

Symptom	Possible Cause	Solution
<p><b><u>Three-phase units only:</u></b>  <b>Platform does not rise.</b>  <b>Motor hums, but does not run.</b></p>	<p>No voltage is present on one line.</p> <p><b>Note:</b> A motor that is missing voltage on one line is said to be single-phased.</p>	<p>Check for blown fuses at branch circuit disconnect. Replace fuse. Determine cause of blown fuse.</p>
		<p>Check motor starter as follows:</p> <ol style="list-style-type: none"> <li>1. Disconnect wires at load side of starter.</li> <li>2. Energize the starter.</li> <li>3. Measure line-to-line voltage at line side of starter.</li> <li>4. Measure line-to-line voltage at load side of starter.</li> <li>5. Line-side and load-side voltages should be approximately the same. Replace starter if voltage values are considerably different from one another.</li> </ol>
		<p>Check all wiring to motor for high resistance or no connection.</p>
<p><b><u>Three-phase units only:</u></b>  <b>Platform does not rise.</b>  <b>Motor runs in reverse</b></p>	<p>Phase reversed.</p>	<p>Reverse any two legs at the branch circuit disconnect.</p>
<p><b><u>Single-phase units only:</u></b>  <b>Platform does not rise.</b>  <b>Motor energizes, but does not run.</b></p>	<p>Line voltage too low.</p>	<p>Check wiring to motor for high resistance. Check for loose or corroded connections. Check if gauge of wires to motor are of correct size and specification for load requirement. Replace if necessary.</p>
	<p>Faulty motor centrifugal switch.</p>	<p>Replace motor.</p>
	<p>Faulty motor capacitor.</p>	<p>Replace motor.</p>
<p><b><u>Units equipped with ARTD only:</u></b>  <b>Platform does not automatically return to the cross-traffic position or operates abnormally.</b></p>	<p>Auto return proximity switch not sensing target correctly.</p>	<p>Adjust proximity switch and target as necessary. See Adjust Auto Return To Dock (ARTD) on pages 34-36.</p>
	<p>Faulty proximity switch.</p>	<p>Replace switch.</p>
	<p>Loose/corroded wire connections or broken wire.</p>	<p>Repair or replace wires and connections as necessary.</p>

# TROUBLESHOOTING

Symptom	Possible Cause	Solution
Platform does not rise. Pump operates in pressure relief mode.	Heavy object(s) on platform.	Remove object(s) from platform. <b>Note:</b> For safety reasons, the dock leveler is designed to lift only the platform's own weight.
	Dock leveler binds.	Check for visible obstructions that could cause binding. Remove obstructions. If no obstructions found, contact Systems, LLC Technical Services.
	Pressure relief set too low.	Increase pressure relief. See page 30 for instruction. <b>Note:</b> The pressure relief valve must not be set at a level that causes the motor operating current to exceed the full load amp value* at any time, including when operating in pressure relief.  <i>* The full load amp value can be found on the inside cover of the control panel.</i>
Platform rises slowly.	Low hydraulic fluid.	Add hydraulic fluid, see pages 28-29 for proper fluid level and type.
	Contaminated hydraulic system.	Clean and inspect valves. Flush contaminated oil from hydraulic system. Fill system with new oil; see pages 28-29 for proper fluid level and type.
	Damage or blocked hydraulic hose(s) and/or valve(s).	Replace damaged hose(s). Check and remove blockage from hose(s) and/or valve(s).
	Pressure relief set too low.	Increase pressure relief. See page 30 for instruction. <b>Note:</b> The pressure relief valve must not be set at a level that causes the motor operating current to exceed the full load amp value* at any time, including when operating in pressure relief.  <i>* The full load amp value can be found on the inside cover of the control panel.</i>
Pump motor loads down when platform reaches the full raised position.	Pressure relief set too high.	Decrease pressure relief. See page 30 for instruction. <b>Note:</b> The pressure relief valve must not be set at a level that causes the motor operating current to exceed the full load amp value* at any time, including when operating in pressure relief.  <i>* The full load amp value can be found on the inside cover of the control panel.</i>

# TROUBLESHOOTING

Symptom	Possible Cause	Solution
<b>Platform does not rise to full height.</b>	Low hydraulic fluid.	Add hydraulic fluid, see pages 28-29 for proper fluid level and type.
<b>Platform DOES rise to full height, but lip DOES NOT extend or extend fully.</b>	Low hydraulic fluid.	Add hydraulic fluid, see pages 28-29 for proper fluid level and type.
	Logic block (valve) lever cable weight too low on cable.	Adjust cable weight. See Adjust Cable Weight and Down Speed Control on page 31.
<b>Lip does not extend.</b>	Logic block spool valve stuck in the up position, or valve lever binding and preventing lever from pushing spool down.	<p>Apply penetrating oil to spool area and valve lever pivot at top of logic block.</p> <p>If necessary, disconnect the valve lever from logic block. Move spool valve up and down until spool valve slides freely. If the spool valve cannot be made to slide freely, replace spool valve.</p> <p>Lubricate valve lever pivot with white lithium grease.</p>
<b>Lip extends almost immediately when the RAISE button is depressed. Platform rises after lip is fully extended.</b>	Logic block spool valve stuck in the down position, or valve lever binding and causing lever to prematurely push the spool down.	<p>Apply penetrating oil to spool area and valve lever pivot at top of logic block.</p> <p>If necessary, disconnect the valve lever from logic block. Move spool valve up and down until spool valve slides freely. If the spool valve cannot be made to slide freely, replace spool valve.</p> <p>Lubricate valve lever pivot with white lithium grease.</p>
<b>Platform locks into “safety” as platform lowers. Lip drops to vertical position.</b>	Platform lowering speed is too fast.	<p>Adjust platform down speed control. See Adjust Cable Weight and Down Speed Control on page 31.</p> <p><b>Note:</b> Extreme cold weather and/or incorrect hydraulic fluid may also cause cylinder to lock. Decrease down speed to compensate.</p>
	Incorrect or aged hydraulic fluid.	Replace hydraulic fluid, see pages 28-29 for proper fluid level and type.

If additional troubleshooting assistance is required, contact Systems, LLC Technical Services with equipment serial number or customer order number (CO#).

**Technical Service at 800-643-5424 or [techservices@loadingdocksystems.com](mailto:techservices@loadingdocksystems.com)**

# PARTS

## Electrical Parts

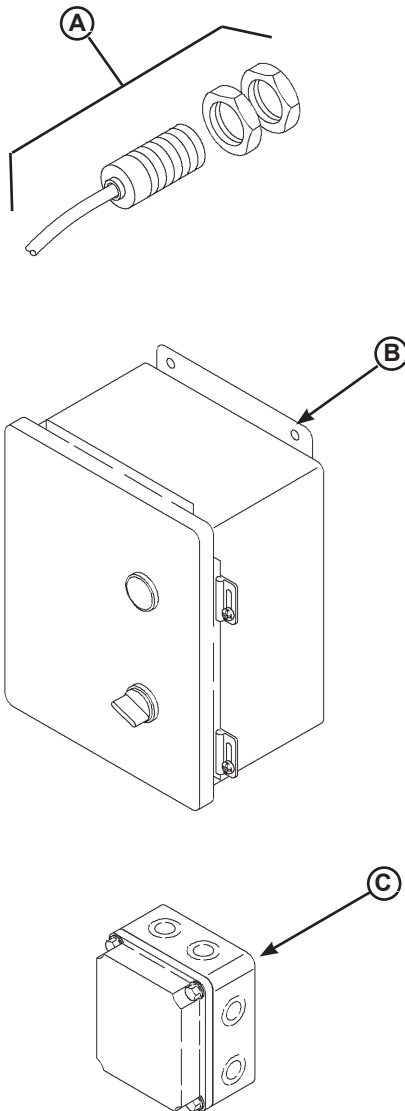

Item	Quantity	Part Number	Description
A	1	0615-0040	Proximity Switch with Harness (ARTD Feature Only)
B	1	*	Control Box
C	1	9511-0004	J-Box, Standard (4 x 4 in. Metal Box)
		9512-0429	J-Box, Cold Weather (5 x 5 in. Plastic Box)

\* Provide dock leveler serial number, voltage, phase, and options when e-mailing, calling or faxing controller orders.

This page intentionally left blank.

# PARTS

## Frame and Platform

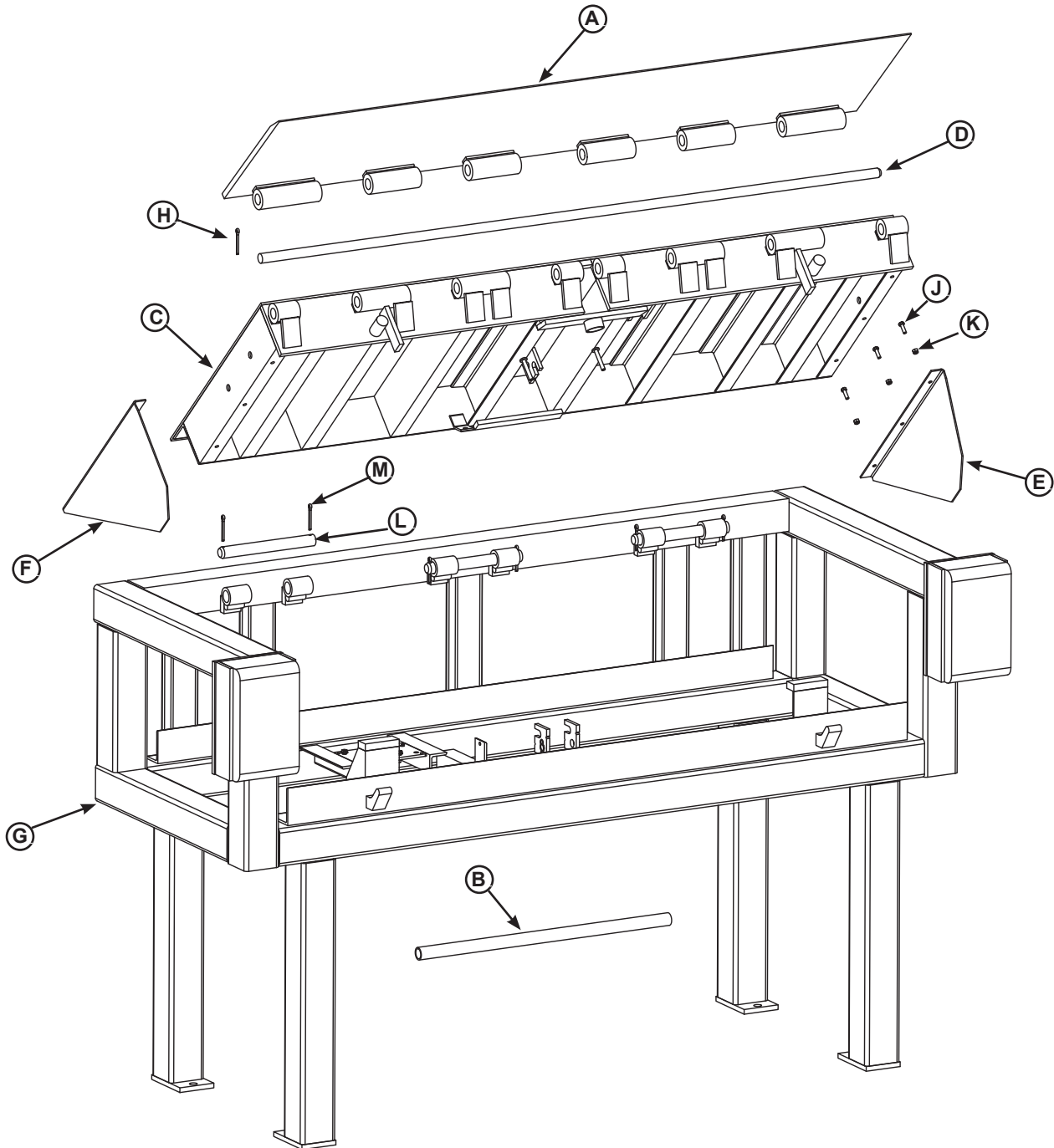



## Frame and Platform

Item	Quantity	Part Number	Description
A	1	0595-____ <sup>1</sup>	Lip, Welded Assembly
B	1	0122-0079	Maintenance Prop
C	1	____ <sup>1</sup>	Platform, Welded Assembly
D	1	____ <sup>1</sup>	6' x 1" Pin, Lip Hinge,
		____ <sup>1</sup>	6-1/2' x 1" Pin, Lip Hinge,
		____ <sup>1</sup>	7' x 1" Pin, Lip Hinge,
E	1	0012-0123 <sup>1</sup>	Toe Guard Welded Assembly, Left
F	1	0012-0124 <sup>1</sup>	Toe Guard Welded Assembly, Right
G	2	____ <sup>1</sup>	Frame, Standard
H	2	2101-0046	Cotter Pin, 1/4 x 1-1/4 in.
J	6	2101-0011	Cap Screw, 5/16-18 UNC x 1 in.
K	6	2101-0039 <sup>1</sup>	Nylon Lock Nut, 5/16-18 UNC
L	3	9202-0002	Rear Hinge Pin
		9202-0009	Rear Hinge Pin (Optional Stainless Steel)
M	6	2101-0047	Cotter Pin, 1/4 x 2 in.

<sup>1</sup> Provide dock leveler serial number, platform size, and lip size when e-mailing, calling or faxing orders.

# PARTS

## Hydraulic Components

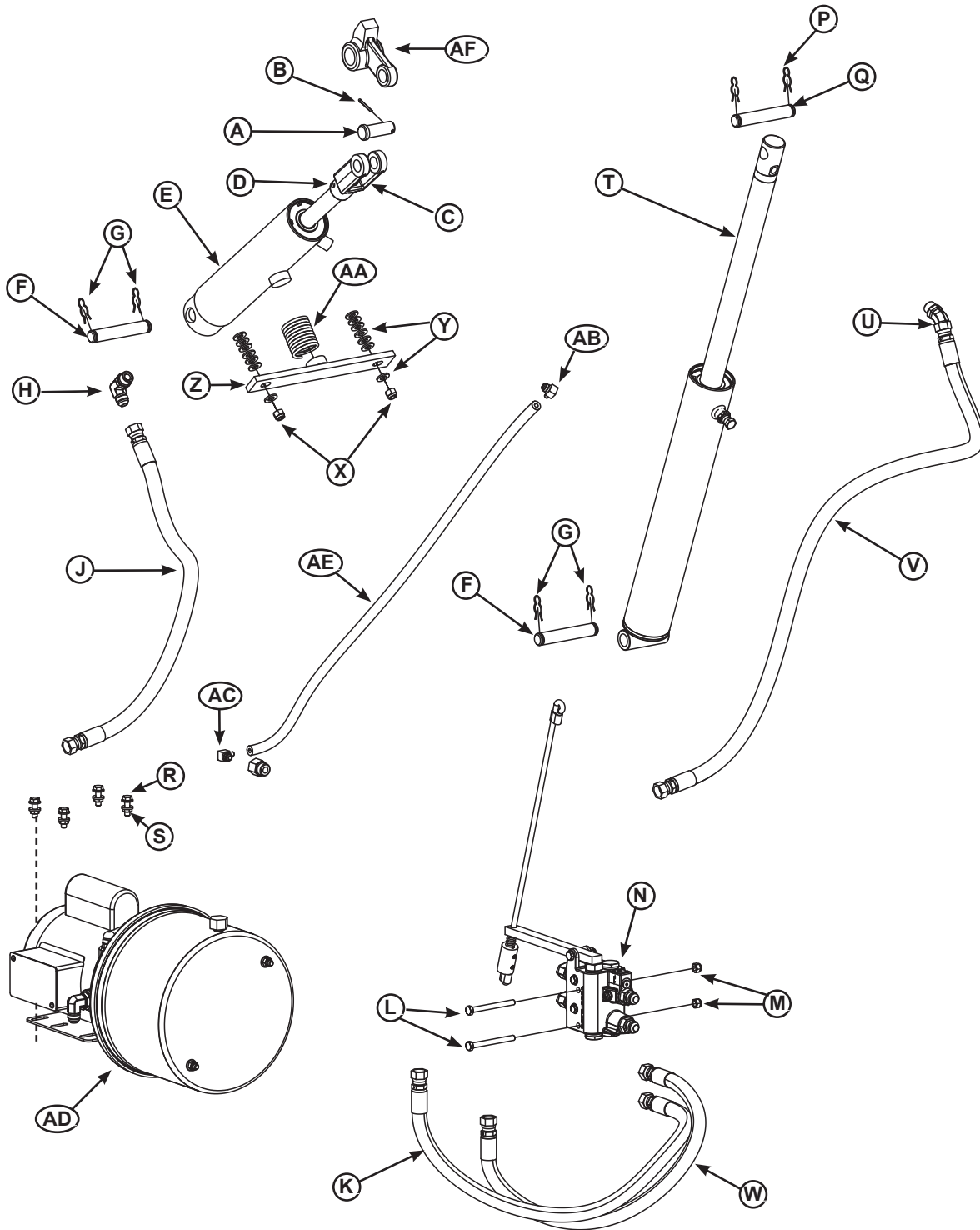

## Hydraulic Components

<sup>1</sup> Provide length and diameter of hose when e-mailing, calling or faxing orders.

<sup>2</sup> Provide length of lip cylinder when e-mailing, calling or faxing orders.

<sup>3</sup> Provide dock leveler serial number, voltage, and phase when e-mailing, calling or faxing orders.

# PARTS

## Platform Cylinder Repair Parts

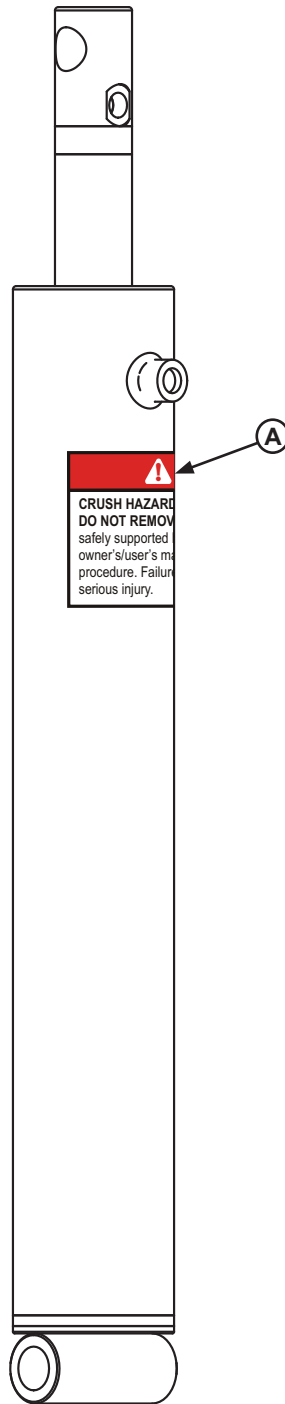

Item	Quantity	Part Number	Description
*	1	0525-0009	Cylinder, Platform, Mini
*	1	0521-0126	Seal Kit, Mini
A	1	1751-0138	Decal

\*Provide dock leveler serial number when e-mailing, calling or faxing orders.

## Lip Cylinder Repair Parts

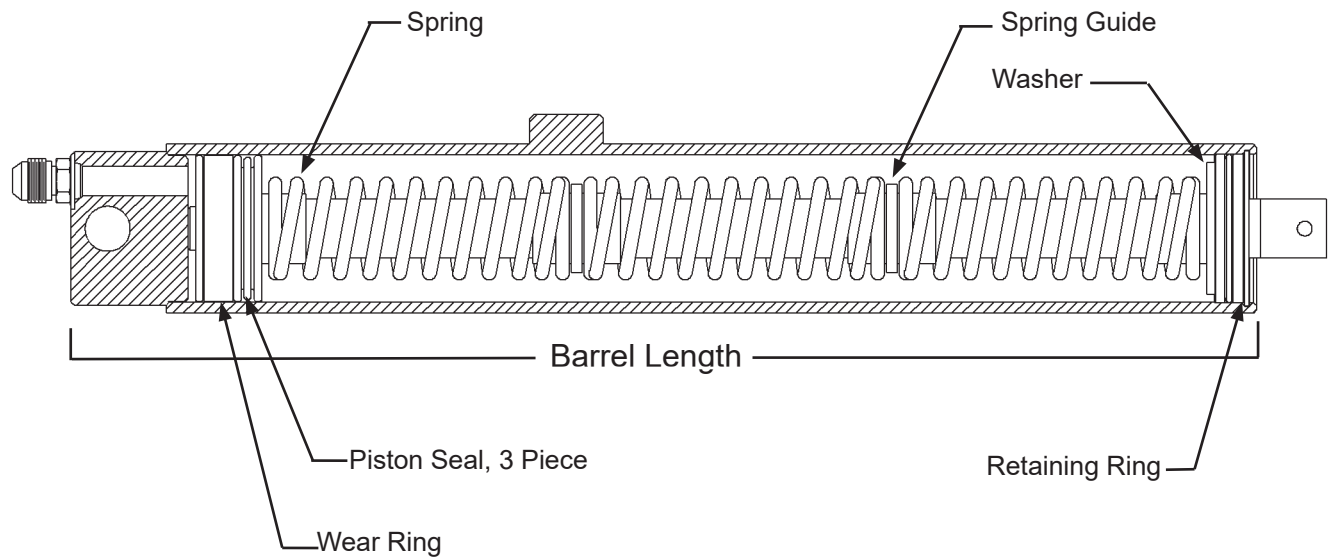

Item	Quantity	Part Number	Description
A	1	0525-0059	Seal Kit, 1992 and Newer Cylinders
		0025-0014	Seal Kit, 1991 and Older Cylinders
B	1	0525-0086	Lip Cylinder, 13-3/4 in. (349 mm) Barrel Length
		0525-0087	Lip Cylinder, 20-1/8 in. (511 mm) Barrel Length

*\*Provide dock leveler serial number when e-mailing, calling or faxing orders.*

# PARTS

## Logic Block Assembly

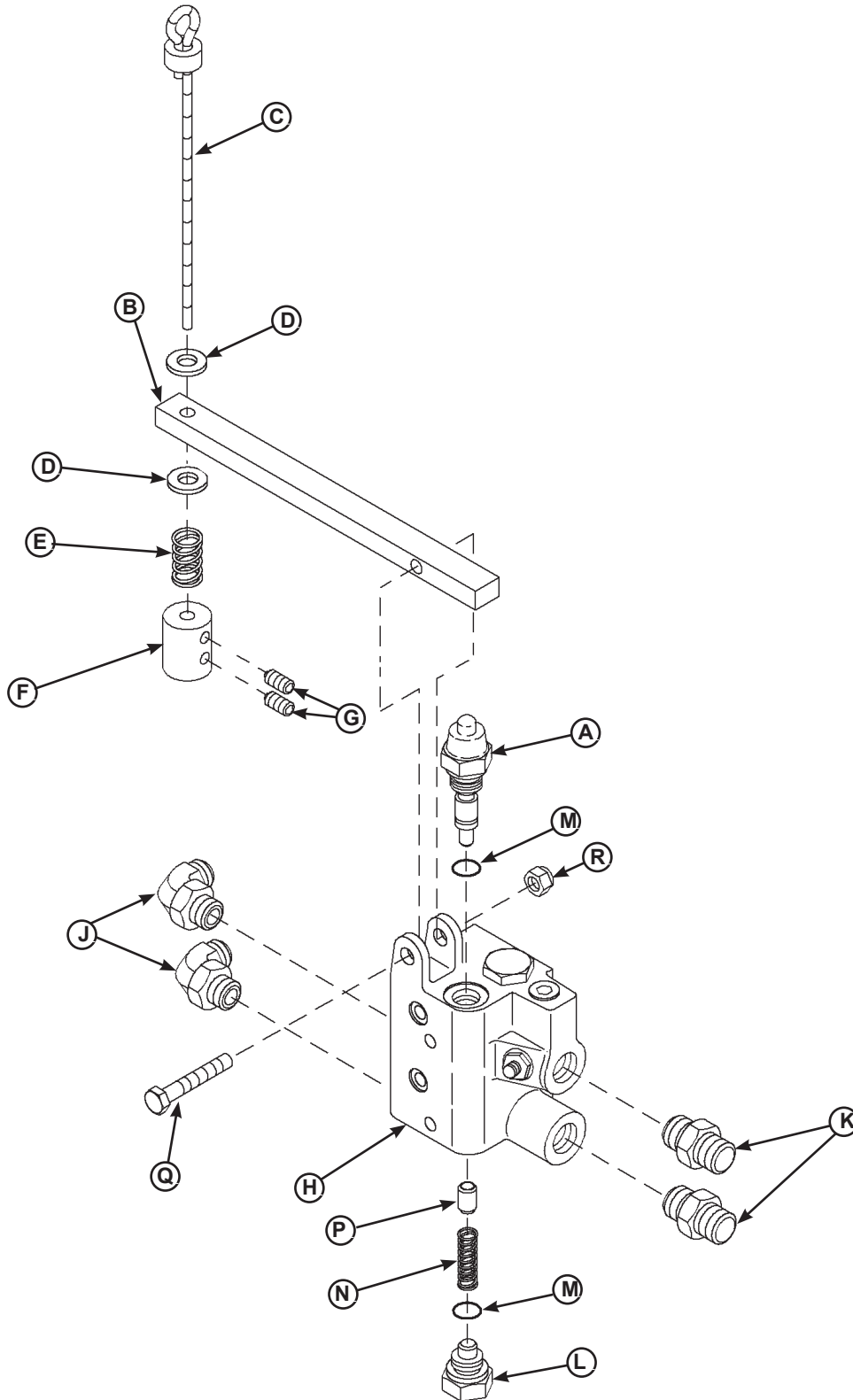

## Logic Block Assembly

<b>Spool Valve and Lever Arm</b>			
<b>Item</b>	<b>Quantity</b>	<b>Part Number</b>	<b>Description</b>
A	1	9574-0001	Spool Valve, Logic Block, Standard
		9574-0002	Spool Valve, Logic Block, Cold Weather
B	1	5402-0007	Lever Arm, Standard
		5455-0004	Lever Arm, Cold Weather

<b>Logic Block Cable Assembly</b>			
<b>Item</b>	<b>Quantity</b>	<b>Part Number</b>	<b>Description</b>
	1	<b>5265-0002</b>	<b>Cable Weight Assembly, Logic Block (Includes Items C – H)</b>
C	1	7955-0001	Cable Subassembly, Logic Block
D	2	2101-0059	Washer, 1/4 in.
E	1	9572-0004	Spring
F	1	8102-0001	Weight, Logic Block Cable
G	2	2101-0035	Set Screw, Socket-Head, 1/4-20 UNC x 1/2 in.

<b>Logic Block Assembly</b>			
<b>Item</b>	<b>Quantity</b>	<b>Part Number</b>	<b>Description</b>
<b>H</b>	<b>1</b>	<b>9575-0007</b>	<b>Logic Block, Complete (Includes Items A and L – N)</b>
J	2	9391-0116	Elbow, #8-ORB Male x #8-JIC Male
K	2	9301-0112	Fitting, #8-ORB Male x #8-JIC Male
L	1	9572-0002	Plug, Spool Valve
M	2	9572-0003	Gasket, Spool Valve
N	1	9572-0004	Spring, Spool Valve
P	1	9572-0013	Dowel Pin, Cold Weather/Wash Down Feature Only
Q	1	2101-0014	Cap Screw, 5/16-18 UNC x 2 in.
R	1	2101-0039	Nylon Lock Nut, 5/16-18 UNC

# PARTS

## Power Pack Assembly

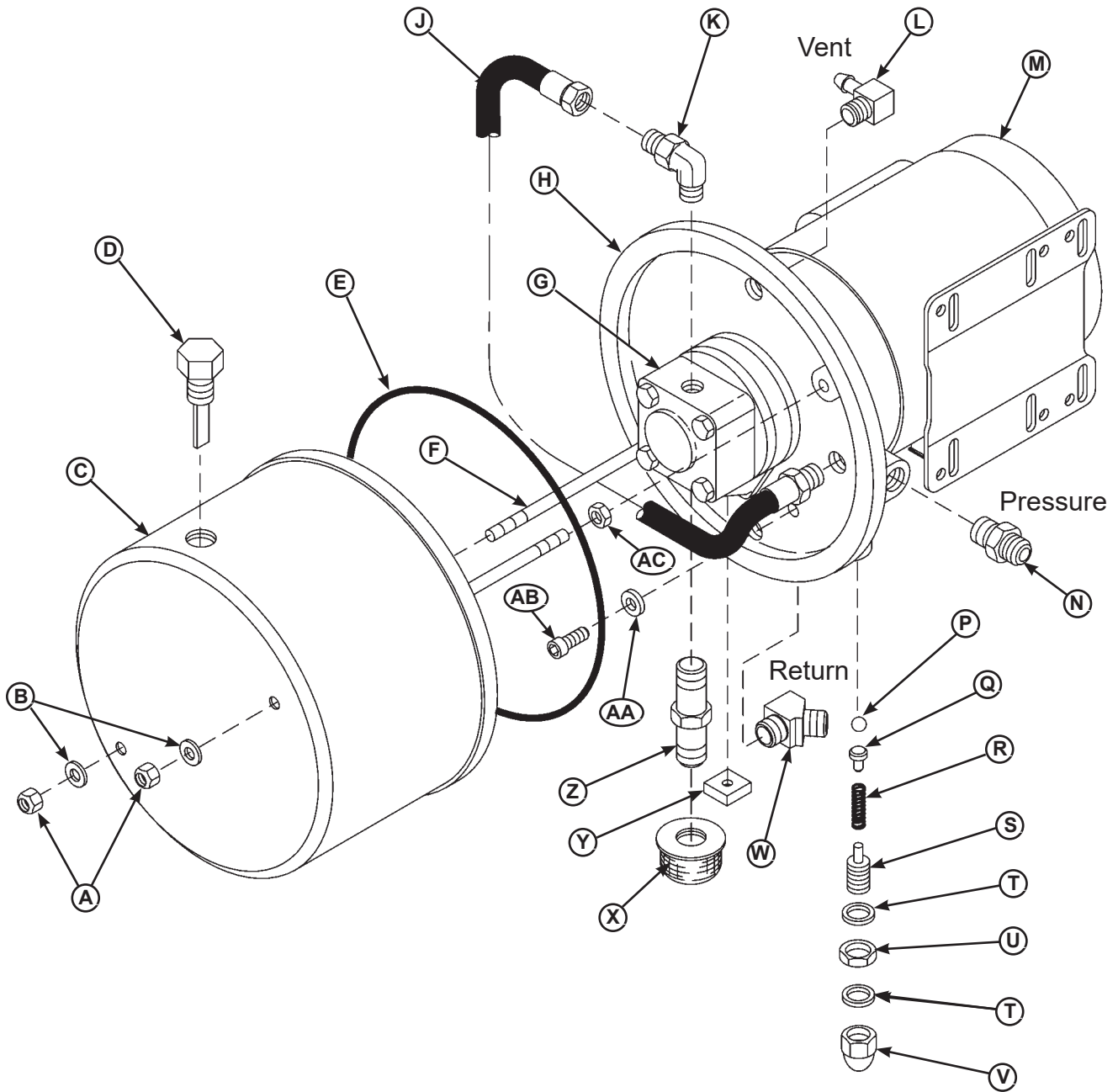



## Power Pack Assembly

Item	Quantity	Part Number	Description
	1	9395-____ <sup>1</sup>	<b>Power Pack Complete (Includes All Items Except L, N, and W)</b>
A	2	2101-0039	Nylon Lock Nut, 5/16-18 UNC
B	2	9301-0029	Seal, Thread
C	1	9302-0014	Reservoir
D	1	9301-0199	Breather Cap, 3/8 NPT Male
E	1	9301-0027	O-Ring (Reservoir)
F	2	9302-0012	Tie Rod (Reservoir)
G	1	9301-____ <sup>1</sup>	Pump Only
	4	2101-0077	Cap Screw, 5/16-18 UNC x 3-1/2 in., Grade 5
	1	9301-0028	Gasket, Pump
	1	9303-0002	Coupling Assembly
H	1	9302-0063	Plate, Drive
J	1	9904-0071	Hose
K	1	0521-0017	90° Elbow, 3/8 NPT Male x #8-JIC Male
L	1	0521-0007	90° Elbow, 1/4 NPT Male x 1/4 Tube
M	1	3411-____ <sup>2</sup>	Motor Only
N	1	9301-0116	90°, Fitting, 3/8 NPT Male x #8-JIC Male
P	1	0521-0014	Ball, Check
Q	1	9301-0024	Guide, Check Ball
R	1	9302-0009	Spring, Relief Valve
S	1	9303-0003	Screw, Adjusting
T	2	9301-0014	Washer, Nylon, 11/16 in. OD x 1/2 in. ID
U	1	9301-0015	Nut, Jam, 1/2-20 UNF
V	1	9301-0016	Nut, Acorn, 1/2-20 UNF
W	1	0521-0017	90° Elbow, 3/8 NPT Male x #8-JIC Male
X	1	9301-0009	Strainer, Suction
Y	1	9301-0082	Magnet
Z	1	9301-0008	Pipe Nipple, 3/8 NPT x 3 in.
AA	2	9301-0003	Washer, Aluminum, 9/16 in. OD x 3/8 in. ID x 1/16 in.
AB	2	9301-0004	Screw, Socket Head, 3/8-16 UNC x 1-3/4 in.
AC	2	2101-0063	Nut, Jam 5/16-18 UNC

<sup>1</sup> Provide dock leveler serial number and type of installation when e-mailing, calling or faxing orders.

<sup>2</sup> Provide dock leveler serial number, voltage, and phase when e-mailing, calling or faxing orders.

# MISCELLANEOUS

---

This page intentionally left blank.

## Customer Information

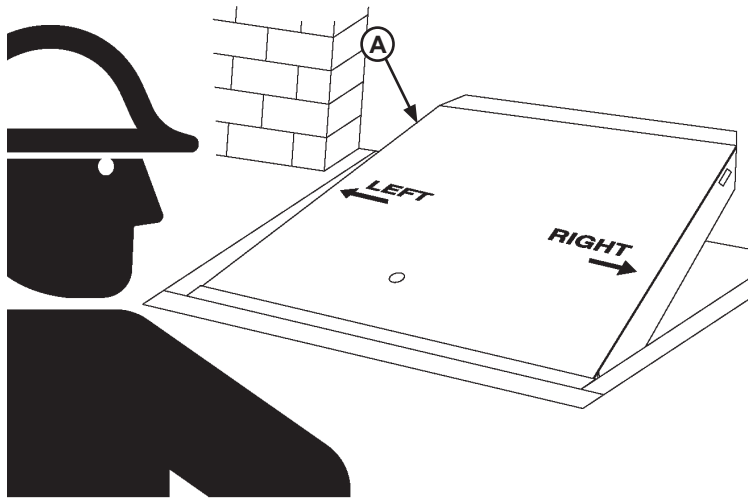

Figure 32

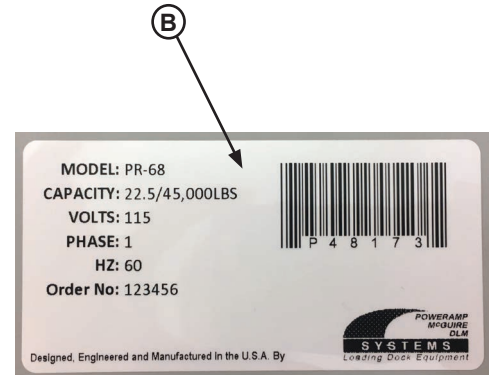

Figure 33

**NOTE:** Refer to **Figure 32** for left/right orientation of dock leveler and **Figure 33** for example of decal.

The **LEVELER** model/serial number decal is located on the left platform joist near the front (lip) of dock leveler (**A**).

When you receive your new equipment, write down the model and serial number in the form provided. This will help ensure safe keeping of the numbers in the event the model/serial number decal (**A, B**) becomes lost or damaged.

Also, write down Systems, LLC's order number, the company that installed the dock leveler, and the original owner's name. This will all help to identify the specific dock leveler if more information is required.

When ordering, use part numbers and description to help identify the item ordered. Do not use "item" numbers. These are only for locating the position of the parts. Always give dock leveler MODEL NUMBER and/or SERIAL NUMBER.

For service, call or contact:

Systems, LLC  
P.O. Box 309  
Germantown, WI 53022

Phone: (800) 643-5424  
Fax: (262) 255-5917

www.loadingdocksystems.com

### Dock Leveler Information

Model \_\_\_\_\_

Serial No. \_\_\_\_\_

Systems, LLC, Job No. \_\_\_\_\_

### Vehicle Restraint Information

Model \_\_\_\_\_

Serial No. \_\_\_\_\_

Systems, LLC Order No. \_\_\_\_\_

### Original Owner Information

Name \_\_\_\_\_

Address \_\_\_\_\_  
\_\_\_\_\_  
\_\_\_\_\_

### Installer Information

Name \_\_\_\_\_

Address \_\_\_\_\_  
\_\_\_\_\_  
\_\_\_\_\_

Date of Installation \_\_\_\_\_

## **STANDARD PRODUCT WARRANTY**

SYSTEMS, LLC warrants that its products will be free from defects in design, materials and workmanship for a period of one (1) year from the date of shipment. All claims for breach of this warranty must be made within 30 days after the defect is or can with reasonable care, be detected. In no event shall any claim be made more than 30 days after this warranty has expired. In order to be entitled to the benefits of this warranty, the product must have been properly installed, maintained and operated in accordance with all manufacturer's recommendations and/or specified design parameters and not otherwise have been subject to abuse, misuse, misapplication, acts of nature, overloading, unauthorized repair or modification, application in a corrosive environment or lack of maintenance. Periodic lubrication, adjustment and inspection in accordance with all manufacturers' recommendations are the sole responsibility of the Owner/User.

In the event of a defect, as determined by SYSTEMS LLC, covered by this warranty, SYSTEMS LLC shall remedy such defect by repairing or replacing any defective equipment or parts, bearing the cost for the parts, labor and transportation. This shall be exclusive remedy for all claims whether based on contract, negligence or strict liability.

## **WARRANTY LIMITATIONS**

THE ABOVE WARRANTIES ARE IN LIEU OF ANY OTHER WARRANTIES, WHETHER EXPRESSED OR IMPLIED, INCLUDING BUT NOT LIMITED TO ANY IMPLIED WARRANTY OF MERCHANTABILITY OR FITNESS FOR A PARTICULAR PURPOSE. SYSTEMS LLC AND ITS SUBSIDIARIES SHALL NOT IN ANY EVENT BE LIABLE TO ANYONE, INCLUDING THIRD PARTIES, FOR INCIDENTAL, CONSEQUENTIAL OR SPECIAL DAMAGES OF ANY KIND INCLUDING BUT NOT LIMITED TO, BREACH OF WARRANTY, LOSS OF USE, LOSS OF PROFIT, INTERRUPTION OF BUSINESS OR LOSS OF GOODWILL.