

PowerHook® Vehicle Restraint Specification Sheet and Submittal

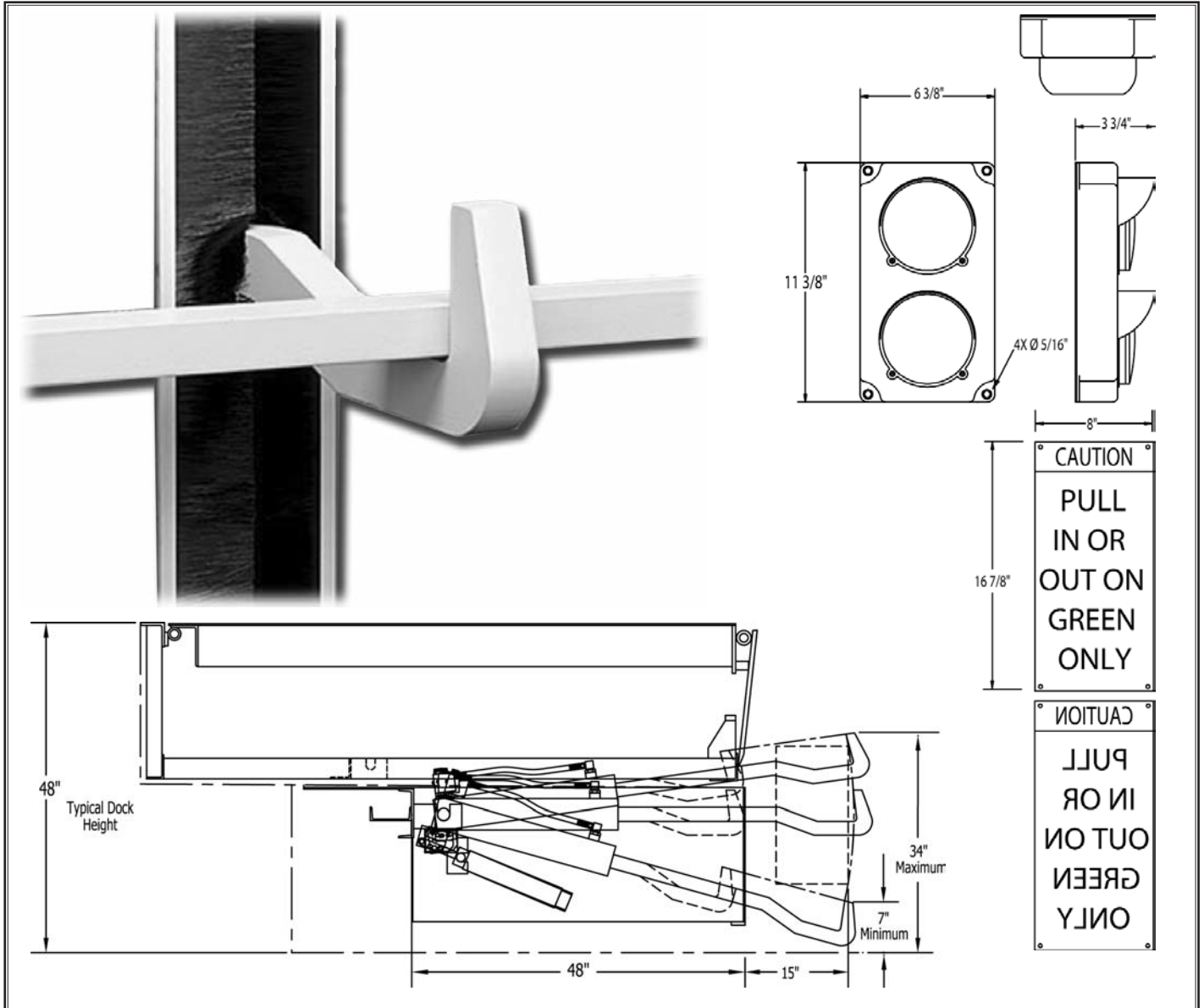

STANDARD FEATURES FOR THE POWERHOOK® VEHICLE RESTRAINT

- Push Button Activation
- Full Recessed Design - For Unobtrusive Access
- Positive Restraining Force To Minimize “Trailer Creep”
- Restraining Force In Excess of 35,000 lbs
- PLC Solid State Controls
- Exterior Strobe Emphasizer
- Amber Light - Caution Indicator
- AutoRestore
- Diagnostic - Fault Indicator Light
- Keyed Override
- Interlock Terminals
- 5 Year Structural Warranty
- 5 Year Hydraulic Warranty



PowerHook® Vehicle Restraint Specification Sheet and Submittal

GENERAL DESCRIPTION: All Poweramp® PowerHook® vehicle restraints are designed to secure a cargo trailer's rear impact guard (RIG) to reduce the likelihood of premature trailer separation during the loading/unloading process. The exclusive PowerHook vehicle restraint features a completely hydraulic restraint mechanism, inside control panel, exterior communication lights and instructional signs.

CONSTRUCTION: The PowerHook restraint system is installed in a box form for permanent placement in a concrete pit or installed as a component of a dock leveler's free-standing frame. The PowerHook remains protected behind the pit wall until activation. Once activated, the PowerHook seeks a RIG and exerts positive pressure which virtually eliminates "trailer creep", securing the trailer with over 35,000 lbs. of pullout force.

OPERATION: As a trailer backs into position, the exterior light is green and the interior light is red. Once the trailer is positioned against the dock bumpers, the operator depresses the "Engage" button. The interior light is amber and the exterior light is red while the restraint is in motion. An exterior strobe light indicator provides additional emphasis to driver during activation, pull-out and by-pass operation. The PowerHook lowers, extends, then seeks out the RIG. Once the trailer is secured the inside light will display green and the outside light will display red. The PowerHook floats freely vertically while the trailer is being loaded/unloaded while providing positive engagement for horizontal forces. After the loading is complete, the operator depresses the "Release" button. When the trailer is released and the restraint is safely stored the interior light changes to red while the exterior light changes to green.

If the PowerHook is unable to secure the trailer's RIG, the restraint automatically stores itself and an amber caution light accompanies the red interior light, indicating an unsafe condition exists. After thirty seconds, the system resets itself automatically. If "By-Pass" of the system is necessary, it is recommended that you secure the trailer by other means before proceeding with the loading/unloading process. In "By-Pass" mode the exterior light is red and a strobe light draws attention to indicate to the driver to remain at the dock area. The interior caution indicator light accompanies the green light indicating to the dock attendant that a caution situation is present. Manual reset of the "By-Pass" is accomplished by depressing the "Release" button.

HYDRAULICS: The PowerHook is a hydraulically actuated restraint with a programmable electronic controller and DockAlert™ communication system. The PowerHook vehicle restraint seeks, finds and maintains a tight, continuous hold on the RIG of truck throughout loading and unloading operations. It is programmed to operate both vertically and horizontally to eliminate any gap between the hook and the RIG, virtually eliminating "trailer creep". As an optional safety feature, the dock leveler and the vehicle restraint can be interlocked, preventing operation of the dock leveler until the hook engages the RIG.

HOOKING RANGE AND CAPACITY: The PowerHook restraint system is designed to withstand a pulling force in excess of 35,000 lbs. giving a added margin of safety and protection. Maximum operational range is 0" to 15" horizontally and 7" minimum to 34" maximum vertically. Extended ranges are available for special applications.

EXTERIOR LIGHTS: Low profile, traffic style, red, green and strobe lights are standard for communication to truck driver. A set of caution signs warns truck driver to "Back In or Pull Out On Green Light Only".

ELECTRICAL: The PowerHook vehicle restraint is available as a stand alone unit or combined electrically and hydraulically with your dock leveler selection. Hydraulic pump and motor is either 1 ½ HP TENV at 120v or 208v single phase or 208v, 230v, 460v or 575v three phase. Electrical control panel is NEMA 4/12 enclosure. All electrical control panel components, connections and wiring are UL listed/ recognized.

Please Note: Unless specifically noted on quotation, all electrical requirements, including mounting of control box, outside lights and signs, are the responsibility of others.

INSTALLATION: Requires mounting of locking unit, control panel, exterior lights and signs in strict accordance with Poweramp installation instructions. Mechanical installation is recommended to be performed only by authorized Poweramp Representative.

WARRANTY: All PowerHook vehicle restraints feature a full two (2) year base warranty on all structural, hydraulic and electrical parts, including freight and labor charges in accordance with Systems, Inc's Standard Warranty Policy. Structural and hydraulic components carry an additional full three (3) year extended warranty with parts and labor. Systems, Inc. warrants all components to be free of defects in materials and workmanship, under normal use, during the warranty period. This base warranty period begins upon the completion of installation or the sixtieth (60th) day after shipment, whichever is earlier.

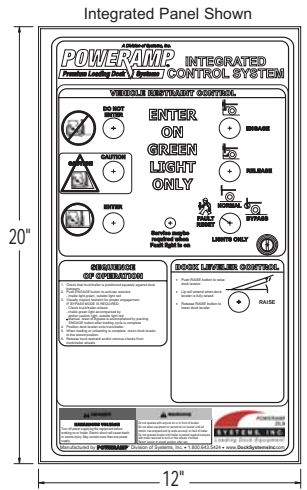

Optional Equipment for PowerHook Vehicle Restraint
(Check options desired)

<input type="checkbox"/> Self-Contained	<input type="checkbox"/> Remote PowerPack
<input type="checkbox"/> Combination Leveler/Restraint w/Box Form	<input type="checkbox"/> L.E.D. External Lights Only
<input type="checkbox"/> Combination Leveler/Restraint w/FreeStanding Frame	<input type="checkbox"/> Dual Incoming Voltage
<input type="checkbox"/> Combination VS Series Leveler/Restraint w/Box Form	<input type="checkbox"/> Limit Switches Door Interlocks
<input type="checkbox"/> CentraPower	<input type="checkbox"/> Other _____
<input type="checkbox"/> Integrated Control Panel	<input type="checkbox"/> Other _____
<input type="checkbox"/> L.E.D. Internal Lights Only	<input type="checkbox"/> Other _____
<input type="checkbox"/> L.E.D. Interior & Exterior Lights	<input type="checkbox"/> Other _____
<input type="checkbox"/> Special Nema Control Type	<input type="checkbox"/> Other _____
<input type="checkbox"/> Extended Range Hook	<input type="checkbox"/> Other _____

<p>Customer: _____</p> <p>Job: _____</p> <p>Location: _____</p> <p>Number of Units: _____</p> <p>Voltage/Phase: _____</p> <p>Represented By: _____</p> <p>SalesRep: _____</p>	<p>Certified For Construction:</p> <p>By: _____</p> <p>Date: _____</p> <p>Company: _____</p> <p>City & State: _____</p> <p>Drawing #: _____</p>
---	---

A continuing product improvement process is in effect at Systems, LLC. We reserve the right to make product changes without prior notice.